



## 3 SERIES



## Centrifugal Pumps



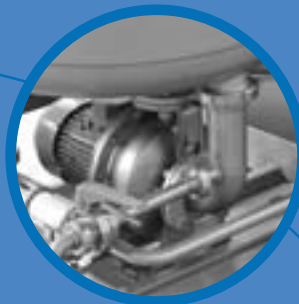



<b>SPECIFICATIONS</b>	pag. 4
Applications	pag. 4
Technical features	pag. 4
Range of application	pag. 4
Materials	pag. 4
Standard motor data	pag. 4
Three available versions	pag. 4
Type key	pag. 5
Pump	pag. 5
Optional on request	pag. 5
<b>MOTOR SPECIFICATIONS</b>	pag. 6
<b>ELECTRICAL DATA</b>	pag. 8
<b>NOISE LEVEL</b>	pag. 10
<b>EBARA TECHNOLOGY</b>	pag. 11
<b>SELECTION CHART</b>	pag. 12
2 poles	pag. 12
4 poles	pag. 13
<b>PERFORMANCE CURVES - 2 POLES</b>	pag. 14
<b>PERFORMANCE CURVES - 4 POLES</b>	pag. 26
<b>SECTIONAL VIEW</b>	pag. 38
<b>DIMENSIONS</b>	pag. 41
<b>MECHANICAL SEAL</b>	pag. 55
<b>INSTALLATIONS</b>	pag. 58
Possible positions of installation	pag. 58
On request special position of terminal box	pag. 59



#### THREE AVAILABLE VERSIONS

Realized in three structural shapes in order to satisfy the most wide range of exigencies for the industrial applications:



**3M:** close-coupled construction with the impeller directly splined to the motor shaft

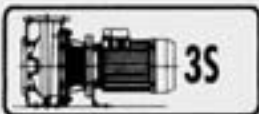

**3S:** close-coupled construction connection of the pump with standard motor with the impeller splined to the motor by a rigid coupling



**3P:** pedestal type pump with support, connected to the motor by elastic coupling, supporting base standard motor, in compliance with EN 733



**3SF:** pump preset for coupling with standard motor B5 - B35

**3PF:** pump with support preset for coupling with standard motor B3

**Centrifugal flanged electropumps, standardized according to EN 733 and built in stainless steel AISI 304 (AISI 316).**

#### APPLICATIONS

- washing systems
- enological and food systems
- water treatment systems
- pumping of fluids reasonably aggressive
- conditioning systems
- heating systems
- pressure increase in industrial systems
- systems for air treatment/humidification

#### TECHNICAL FEATURES

- Robust hydraulic construction
- Versatile, it is possible to handle a wide range of fluid (304 or 316 version)
- Volute casing for high efficiency
- With AISI 304 pump pump foot as standard
- All pump casing fixed screw in AISI 304
- Compact design
- Wide range of performances with 2-4 poles motor
- Standard dimension as ISO EN 733
- Back pull out design - easy to dismantle, pump casing remain to the pipe
- Standard mechanical seal DIN 24960
- Standard IEC motor (3S - 3P)
- Special motor: atex, high efficiency EFF 1, low noise motor, with integrated inverter VMA (see VMA catalogue)
- Other customize solutions to meet all your needs

#### RANGE OF APPLICATION

- Capacity up to 132 m<sup>3</sup>/h
- Head up to 72 m
- Maximum working pressure: 10 bar
- Temperature of the liquid: from -10°C to 90°C standard  
-20° +110°C in H version

#### MATERIALS

- Pump casing, impeller, casing cover and shaft in AISI 304 (series 3), in AISI 316L (series 3L)
- Mechanical seal in carbon/standard/ceramic/NBR (series 3), in SiC/SiC/FPM (series 3L)
- Mechanical seal version H in carbon/ceramic/Viton
- Mechanical seal version HS in SiC/SiC/FPM

#### STANDARD MOTOR DATA

- asynchronous motor 2 poles and 4 poles ventilated
- insulating class F
- protection degree IP55
- mono-phase voltage 230+/- 10%
- three-phase voltage 230+/400V +/-10% 50Hz till 4kW, 400/690V +/- 10% 50Hz for higher powers
- protection edited by the user

### TYPE KEY

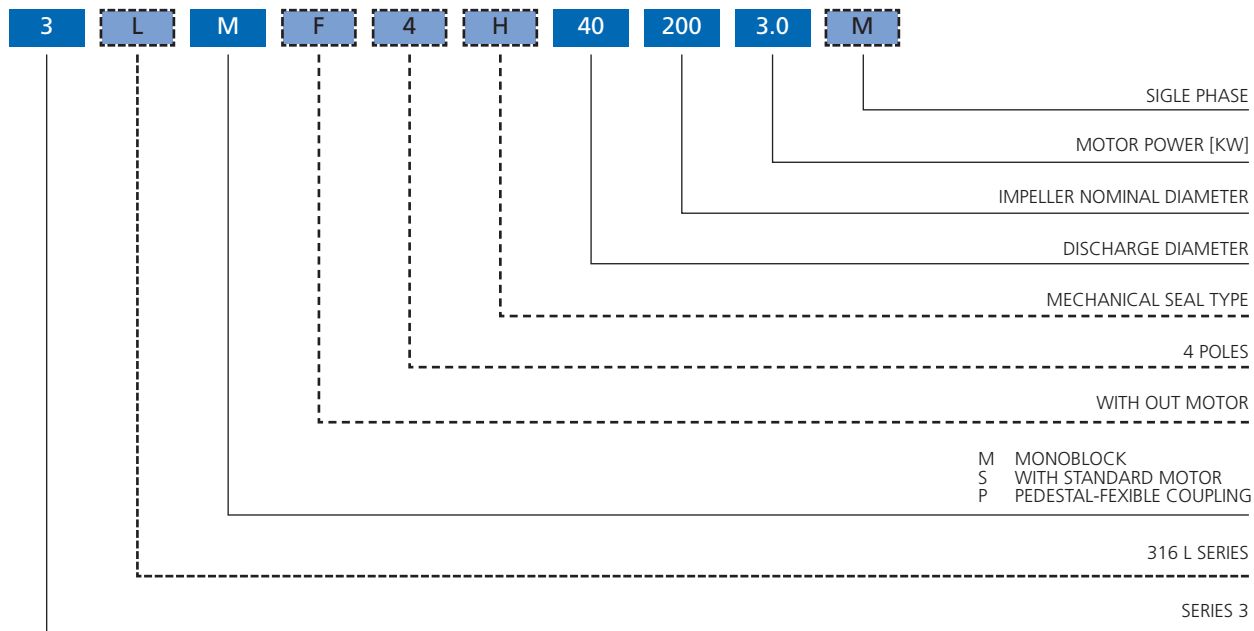

PUMP		
Liquid Handled	Type of liquid	Clean water and moderately aggressive fluids
	Temperature [°C]	min. -10°
		max. +90° standard max. +110° (3MH)-(3MHS)-(3LM)
Maximum working pressure	[MPa]	1
Construction	Impeller	Closed centrifugal type Reinforced laser welding for types 40-200/11, 50-200/15 Casting three dimensioned blades 3M 65
	Shaft seal type	Mechanical seal
	Bearing	Sealed ball bearing with permanent grease
Pipe Connection	Suction-Flange	Flange to DIN 2532 (50mm - 65mm - 80 mm)
	Discharge-Flange	Flange to DIN 2532 (32mm - 40mm - 50mm - 65 mm)
Material	Casing	AISI 304 (AISI 316 3LM)
	Impeller	AISI 304 (AISI 316 3LM)/bronze or micro Casting AISI 316L 3M65
	Casing cover	AISI 304 (AISI 316 3LM)
	Standard mechanical seal	Ceramic/Carbon/NBR (for 3M)
		Ceramic/Carbon/FPM (for 3MH)
		SiC/SiC/FPM (for 3MHS)(3LM)
Shaft	AISI 304 (Part in contact with liquid) (AISI 316 3LM)	
Bracket	Cast iron	
Applicable standard of test		ISO 9906 - Annex A

### OPTIONAL ON REQUEST

#### PUMP

- Pump in 316 (3L version)
- kit counterflanges threading, to weld, galvanized or stainless steel 304 - 316
- impellers with different diameter
- pump casing without foot

- different materials for the friction surface: tungsten carbide, silicon carbide, stainless steel, special impregnated carbon, special ceramic, etc.
- different solutions at a structural level, rubber, bellows seals, with lockpin, etc.

#### MECHANICAL SEALS

- different materials for the elastomers according to the pumped liquid EPDM, FKM, FFKM

**We are at your disposal for evaluating together your specifications and needs in order to find out the solution most suitable for your application.**

3M MOTOR VERSION AISI 304 - (3LM AISI 316)		2 POLES		4 POLES
Type		Electric - TEFC	Electric - TEFC	Electric - TEFC
		Single Phase	Three Phase	Three Phase
No. of Poles		2	2	4
Rotation speed	[min <sup>-1</sup> ]	≈2800	≈2800	≈1400
Insulation Class		F	F	F
Protection degree		IP 55	IP 55	IP 55
Power Rating	[kW]	1.1 ÷ 2.2	1.1 ÷ 22	0.25 ÷ 3.0
	[HP]	1.5 ÷ 3.0	1.5 ÷ 30	0.33 ÷ 4.0
Frequency	[Hz]	50	50	50
Voltage	[V]	230 ±10%	230/400 ±10% 400/690 ±10% (5.5 kW and above)	230/400 ±10%
Capacitor		Built in	-	-
Over load protection		Built in	Provided by the user	Provided by the user
Casing material		Aluminium	Aluminium	Aluminium

3S MOTOR VERSION AISI 304 - (3LS AISI 316)		2 POLES	4 POLES
Type		Electric - TEFC	Electric - TEFC
		Three Phase	Three Phase
No. of Poles/Speed		2	4
Rotation speed	[min <sup>-1</sup> ]	≈2800	≈1400
Insulation Class		F	F
Protection degree		IP 55	IP 55
Power Rating	[kW]	1.1 ÷ 22	0.25 ÷ 3.0
	[HP]	1.5 ÷ 30	0.33 ÷ 4.0
Frequency - Hz	[Hz]	50	50
Voltage	[V]	230/400 ±10% (up to 4.0 kW) 400/690 ±10% (5.5 kW and above)	230/400 ±10% (4.0 kW)
Over load protection		Provided by the user	Provided by the user
Casing material		Aluminium	Aluminium
Mounting arrangements (IEC motor) 3S		IM B5 (up to 2.2 kW) IM B35 (3.0 kW and above)	IM B5 (up to 1.5 kW) IM B35 (2.2 kW ÷ 3 kW)

3P MOTOR VERSION AISI 304 - (3LP AISI 316)		2 POLES	4 POLES
Type		Electric - TEFC	Electric - TEFC
		Three Phase	Three Phase
No. of Poles/Speed		2	4
Rotation speed	[min <sup>-1</sup> ]	≈2800	≈1400
Insulation Class		F	F
Protection degree		IP 55	IP 55
Power Rating	[kW]	1.1 ÷ 22	0.25 ÷ 3.0
	[HP]	1.5 ÷ 30	0.33 ÷ 4.0
Frequency - Hz	[Hz]	50	50
Voltage	[V]	230/400 ±10% (4.0 kW) 400/690 ±10% (5.5 kW and above)	230/400 ±10% (4.0 kW)
Over load protection		Provided by the user	Provided by the user
Casing material		Aluminium	Aluminium
Mounting arrangements (IEC motor)		IM B3	IM B3

Standard motors for ambient temperatures till 40°C and altitude till 1000 m.  
For different applications, please contact our Sales Dept.

## ON REQUEST

### MOTORS

Special versions on demand:

- motors of different builders for the versions 3S-3P
- motors with different voltages and frequencies
- motors conforming with UL/CSA (3S-3P)
- motor with integrated inverter (see catalogue VMA)
- motors EFF 1 - according with CEMEP
- motors ATEX (3S-3P)
- different position of the motor terminal board
- tropicalized motors
- motors with cast-iron casing
- souped-up engine with superior power
- silent motors
- bipolar motors
- motors with 6 poles (3S-3P)
- motors with different protection degree IP
- motors with insulating class H

Pump type		Power		Motor		Capacitor		Input		Full load current		
Single Phase 50 Hz	Three Phase 50 Hz	kW	HP	Size	Type	Single Phase m F	Vc	Single Phase	Three Phase	230 V	400 V	690 V
3M 32-125/1.1 M	3M 32-125/1.1	1,1	1,5	90	-	31,5	450	1,47	1,45	5	2,9	-
3M 32-160/1.5 M	3M 32-160/1.5	1,5	2	90	-	40	450	2,09	2	5,9	3,4	-
3M 32-160/2.2 M	3M 32-160/2.2	2,2	3	90	-	50	450	2,77	2,8	8,3	4,8	-
-	3M 32-200/3.0	3	4	90	-	-	-	-	3,7	11,8	6,8	-
	3M 32-200/4.0	4	5,5	100	-	-	-	-	5	15,6	9	-
	3M 32-200/5.5	5,5	7,5	112	-	-	-	-	6,8	-	11,8	6,8
3M 40-125/1,5 M	3M 40-125/1.5	1,5	2	90	-	40	450	2,01	2	5,9	3,4	-
3M 40-125/2.2 M	3M 40-125/2.2	2,2	3	90	-	50	450	2,9	2,8	8,3	4,8	-
-	3M 40-160/3.0	3	4	90	-	-	-	-	3,7	11,8	6,8	-
	3M 40-160/4.0	4	5,5	100	-	-	-	-	5,1	15,9	9,2	-
	3M 40-200/5.5	5,5	7,5	112	-	-	-	-	6,7	-	11,1	6,4
	3M 40-200/7.5	7,5	10	112	-	-	-	-	8,8	-	15,1	8,7
	3M 40-200/11	11	15	132	-	-	-	-	11,5	-	20	11,6
3M 50-125/2.2 M	3M 50-125/2.2	2,2	3	90	-	50	450	2,73	2,8	8,1	4,7	-
-	3M 50-125/3.0	3	4	90	-	-	-	-	3,7	11,8	6,8	-
	3M 50-125/4.0	4	5,5	100	-	-	-	-	5,1	15,9	9,2	-
	3M 50-160/5.5	5,5	7,5	112	-	-	-	-	6,7	-	11,5	6,6
	3M 50-160/7.5	7,5	10	112	-	-	-	-	9,1	-	15,5	9
	3M 50-200/9.2	9,2	12,5	132	-	-	-	-	10,9	-	17,4	10
	3M 50-200/11	11	15	132	-	-	-	-	13	-	22	12,7
	3M 50-200/15	15	20	160	-	-	-	-	17,5	-	31,3	18
-	3M 65-125/4	4	5,5	100	-	-	-	-	4,69	13,8	8	-
	3M 65-125/5.5	5,5	7,5	112	-	-	-	-	6,41	-	11	6,3
	3M 65-125/7.5	7,5	10	112	-	-	-	-	8,72	-	14,9	8,6
	3M 65-160/7.5	7,5	10	112	-	-	-	-	8,72	-	14,9	8,6
	3M 65-160/9.2	9,2	12,5	132	-	-	-	-	10,9	-	20,8	12,1
	3M 65-160/11	11	15	132	-	-	-	-	13	-	27	15,6
	3M 65-160/15	15	20	160	-	-	-	-	17,7	-	30,5	17,6
	3M 65-200/15	15	20	160	-	-	-	-	17,7	-	30,5	17,6
	3M 65-200/18.5	18,5	25	160	-	-	-	-	20,6	-	36,9	21,3
3M 65-200/22	22	30	160	-	-	-	-	24,3	-	40,8	23,5	



#### DIAGRAM AND ELECTRIC CONNECTIONS THREE PHASE MOTOR

STAR CONNECTION

DELTA CONNECTION

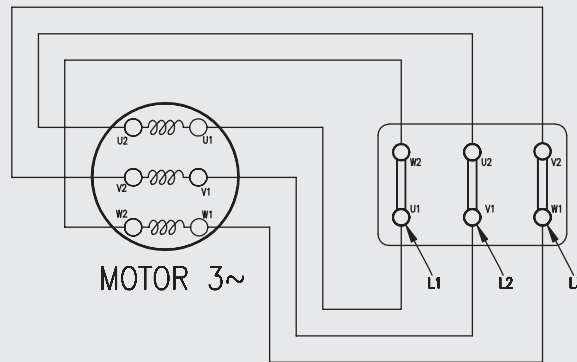
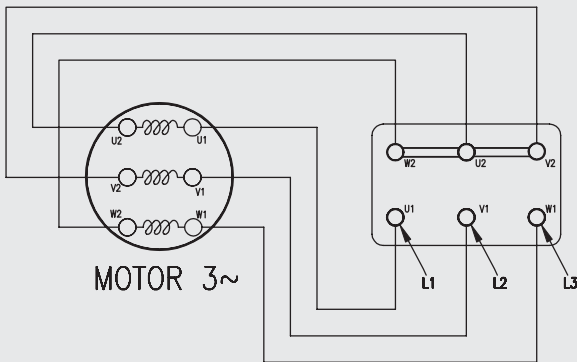

FOR MOTOR UP TO 4 kW

DELTA CONNECTION 230 V

STAR CONNECTION 400 V

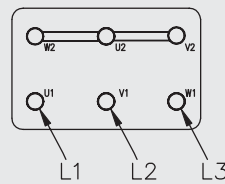
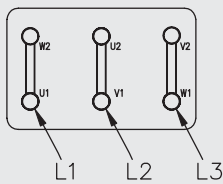

FOR MOTOR 5.5 kW AND ABOVE

DELTA CONNECTION 400 V

STAR CONNECTION 690 V

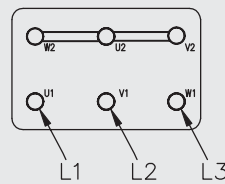
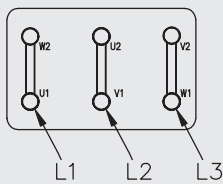

#### SOUND PRESSURE LEVEL

Power kW	MOTOR		2 POLES 50 Hz		2 POLES 60 Hz	
	3M Mec	3S-3P Mec	3M LpA - dB (A)*	3S-3P LpA - dB (A)*	3M LpA - dB (A)*	3S-3P LpA - dB (A)*
1.1	90	90	< 70	< 70	72	72
1.5	90	90	< 70	< 70	72	72
2.2	90	90	< 70	< 70	72	72
3	100	100	71	71	76	76
4	100	112	71	75	76	80
5.5	112	132	75	80	80	85
7.5	112	132	75	80	80	85
9.2	132	132	80	80	85	85
11	132	160	80	83	85	88
15	132	160	80	83	85	88
15	160	160	83	83	88	88
18.5	160	160	83	83	88	88
22	160	180	83	84	88	89

Power kW	MOTOR		4 POLES 50 Hz	
	3M Mec	3S-3P Mec	3M LpA - dB (A)*	3S-3P LpA - dB (A)*
Up to 3 kW	71-100	71-100	< 70	< 70

\* Average measure: 1 m far from the pump. Tolerance  $\pm 2.5$  dB.

## 3M-3S-3P EBARA Advanced Technology

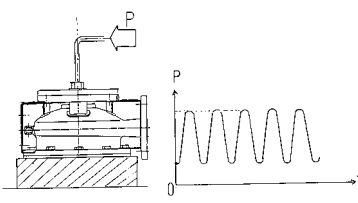

Casing has been tested to a pressure of 14 bar for a test sequence in excess of 1 million cycles.

The hydro-forming process to obtain the integrated volute is patented. The volute offers higher efficiency than circular casing and the absence of a circular welding guarantees a good corrosion resistance.

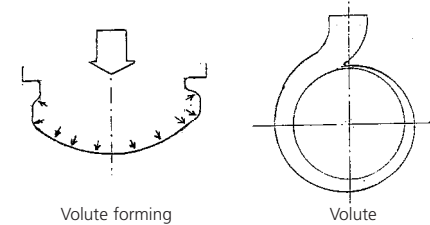

Volute forming                      Volute

High efficiency impeller design - giving efficiencies up to 80%.  
Stamped stainless steel impeller 304 or 316 microcasting stainless steel 316 casting bronz impeller available (65 series).

Hydraulically balanced impeller - reducing axial thrust and prolonging bearing life.

Standard DIN mechanical seal - allowing for a range of seal materials to suit the pumped medium.

Robust structural design - reducing the possible effects of pipe strain and subsequent casing deformation.

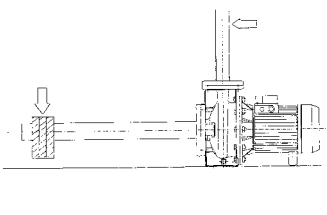
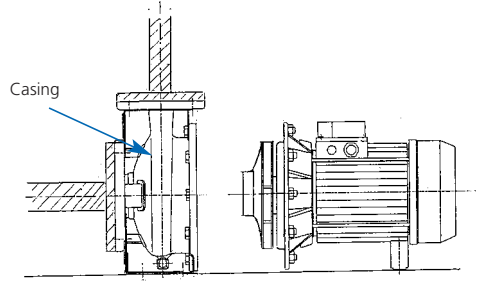
Casing

"Back Pull Out" design - allowing for the removal of the motor/impeller assembly, whilst leaving the casing in situ.



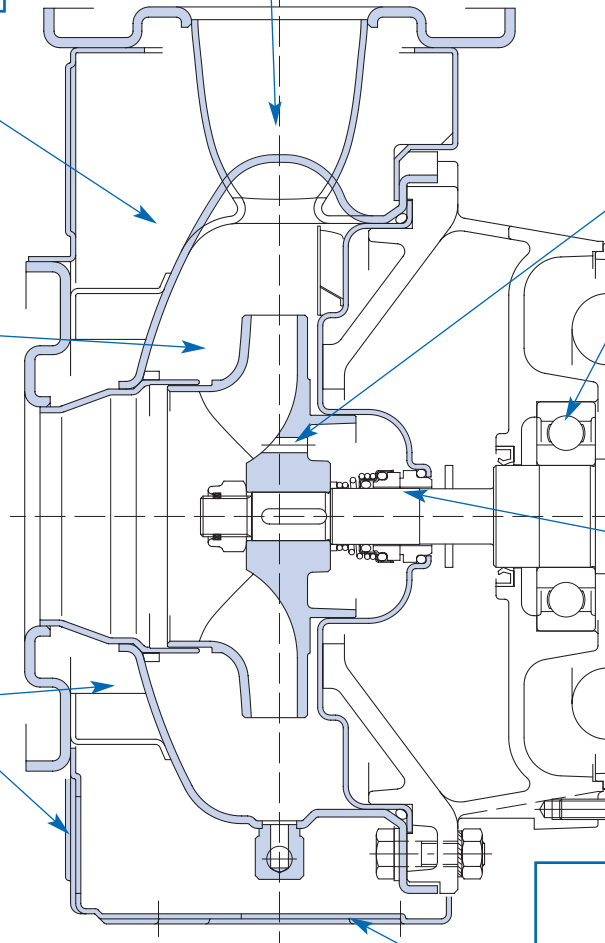

### 4 POLES SELECTION CHART 1400 min<sup>-1</sup> (ISO 9906 Annex A)

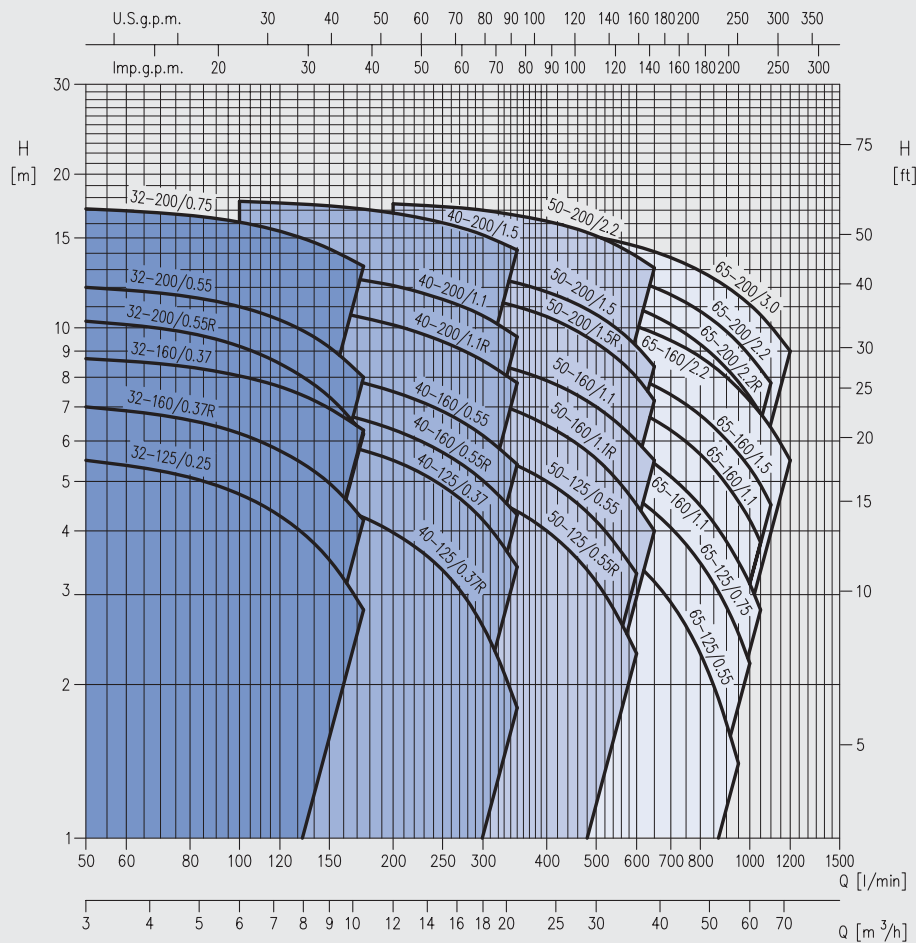

### PERFORMANCE TABLE

Pump type 3M	kW	HP	Q= Capacity																		
			Vmin	50	100	160	200	250	300	350	400	500	600	650	800	950	1000	1050	1100	1200	
			m <sup>3</sup> /h	3	6	9.6	12	15	18	21	24	30	36	39	48	57	60	63	66	72	
			H= Total manometric head in meters																		
32-125/0.25	0,25	0,33	5,6	4,9	3,3	-	-	-	-	-	-	-	-	-	-	-	-	-	-	-	-
32-160/0.37R	0,37	0,5	7,2	6,3	4,5	-	-	-	-	-	-	-	-	-	-	-	-	-	-	-	-
32-160/0.37	0,37	0,5	8,7	8	6,7	-	-	-	-	-	-	-	-	-	-	-	-	-	-	-	-
32-200/0.55R	0,55	0,75	10,5	9,3	7	-	-	-	-	-	-	-	-	-	-	-	-	-	-	-	-
32-200/0.55	0,55	0,75	12	11	9,2	-	-	-	-	-	-	-	-	-	-	-	-	-	-	-	-
32-200/0.75	0,75	1	17,3	16,5	14,6	-	-	-	-	-	-	-	-	-	-	-	-	-	-	-	-
40-125/0.37R	0,37	0,5	-	4,5	4	3,6	3	2,3	1,5	-	-	-	-	-	-	-	-	-	-	-	-
40-125/0.37	0,37	0,5	-	6,2	5,7	5,2	4,6	3,8	3	-	-	-	-	-	-	-	-	-	-	-	-
40-160/0.55R	0,55	0,75	-	7,2	6,7	6,3	5,7	5	4,3	-	-	-	-	-	-	-	-	-	-	-	-
40-160/0.55	0,55	0,75	-	8,5	7,9	7,5	6,9	6,2	5,4	-	-	-	-	-	-	-	-	-	-	-	-
40-200/1.1R	1,1	1,5	-	11	10,5	10,1	9,6	9	8,3	-	-	-	-	-	-	-	-	-	-	-	-
40-200/1.1	1,1	1,5	-	12,7	12,3	11,9	11,2	10,4	9,4	-	-	-	-	-	-	-	-	-	-	-	-
40-200/1.5	1,5	2	-	17,8	17,4	16,9	16,2	15,3	14,2	-	-	-	-	-	-	-	-	-	-	-	-
50-125/0.55R	0,55	0,75	-	-	-	4,9	4,7	4,4	4,2	3,8	3	2	-	-	-	-	-	-	-	-	-
50-125/0.55	0,55	0,75	-	-	-	5,8	5,6	5,4	5,2	4,9	4,1	3,2	-	-	-	-	-	-	-	-	-
50-160/1.1R	1,1	1,5	-	-	-	7,7	7,5	7,2	6,9	6,5	5,6	4,5	-	-	-	-	-	-	-	-	-
50-160/1.1	1,1	1,5	-	-	-	9	8,8	8,5	8,2	7,8	6,9	5,8	-	-	-	-	-	-	-	-	-
50-200/1.5R	1,5	2	-	-	-	12,1	11,8	11,5	11,1	10,6	9,5	8	-	-	-	-	-	-	-	-	-
50-200/1.5	1,5	2	-	-	-	13	12,7	12,3	11,9	11,5	10,5	9,1	-	-	-	-	-	-	-	-	-
50-200/2.2	2,2	3	-	-	-	17,7	17,5	17,2	16,8	16,4	15,4	14	-	-	-	-	-	-	-	-	-
65-125/0.55	0,55	0,75	-	-	-	-	-	4,8	4,4	4,0	3,5	3,2	2,3	1,4	-	-	-	-	-	-	-
65-125/0.75	0,75	1	-	-	-	-	-	6	5,6	5,2	4,6	4,4	3,5	2,5	2,2	-	-	-	-	-	-
65-125/1.1	1,1	1,5	-	-	-	-	-	7,2	7	6,8	6,3	5,8	5,4	4,5	3,5	3,2	2,8	-	-	-	-
65-160/1.1	1,1	1,5	-	-	-	-	-	8,1	8,0	7,4	7,0	6,6	5,7	4,6	4,2	3,8	-	-	-	-	-
65-160/1.5	1,5	2	-	-	-	-	-	9,2	9	8,5	8	7,7	6,7	5,7	5,3	4,9	4,5	-	-	-	-
65-160/2.2	2,2	3	-	-	-	-	-	11,3	11,1	10,6	10	9,8	8,8	7,6	7,2	6,8	6,4	5,5	-	-	-
65-200/2.2R	2,2	3	-	-	-	-	-	12,4	12,2	11,6	11	10,6	9,3	7,8	7,3	6,8	-	-	-	-	-
65-200/2.2	2,2	3	-	-	-	-	-	13,9	13,7	13,0	12,4	12	10,8	9,3	8,8	8,3	7,8	-	-	-	-
65-200/3.0	3	4	-	-	-	-	-	15,8	15,6	15,06	14,5	14,1	12,9	11,6	11,1	10,6	10,1	9	-	-	-

#### 32/125 SERIES

2900 min<sup>-1</sup>

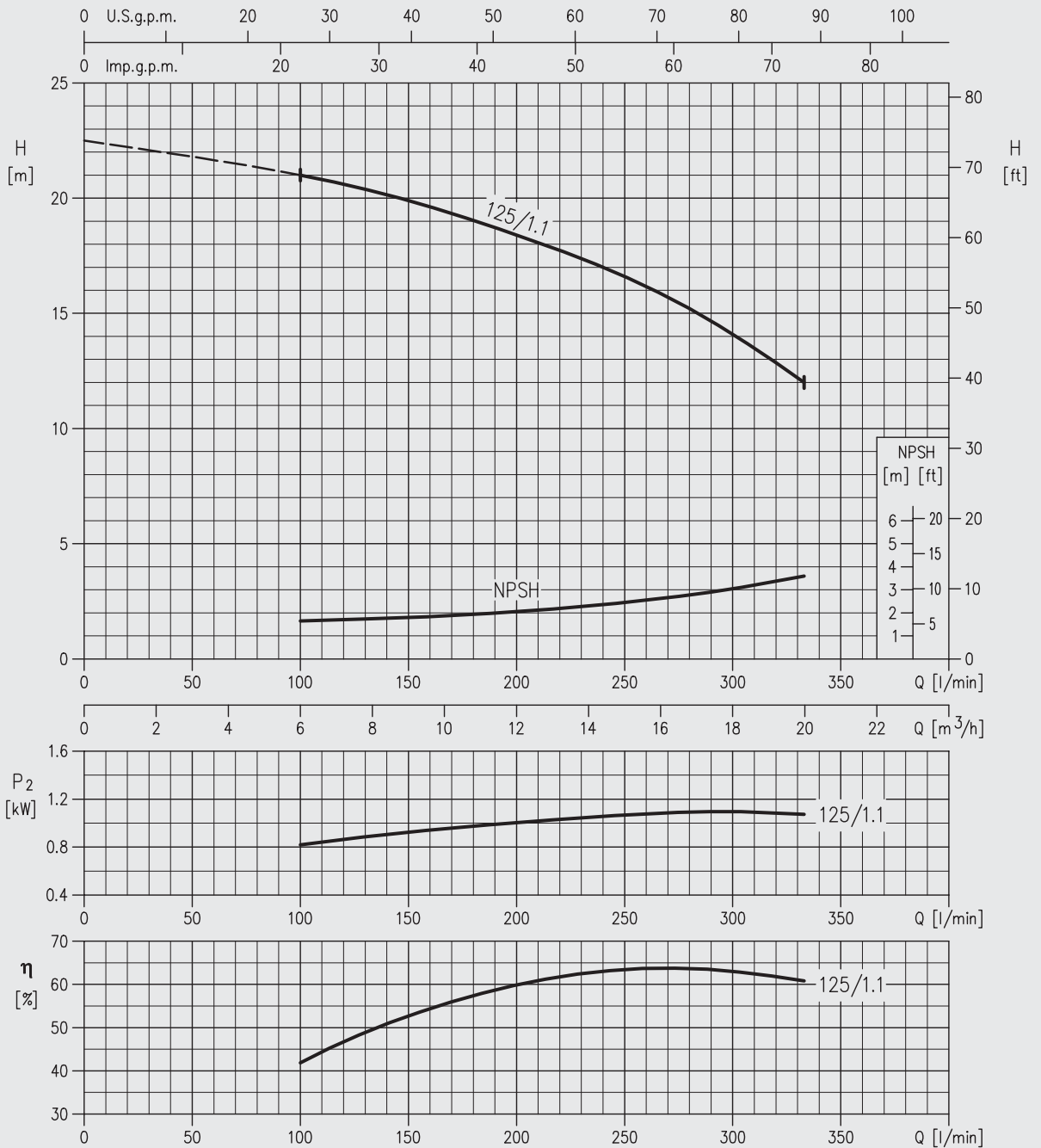

The all hydraulic performances indicated refer to the tests executed with water at 20°C according to standard ISO 9906, annex A. On the values of NPSH indicated, we suggest you to add a security margin of 0,5 m. in order to guarantee the practical working.

#### 32/160 SERIES

2900 min<sup>-1</sup>

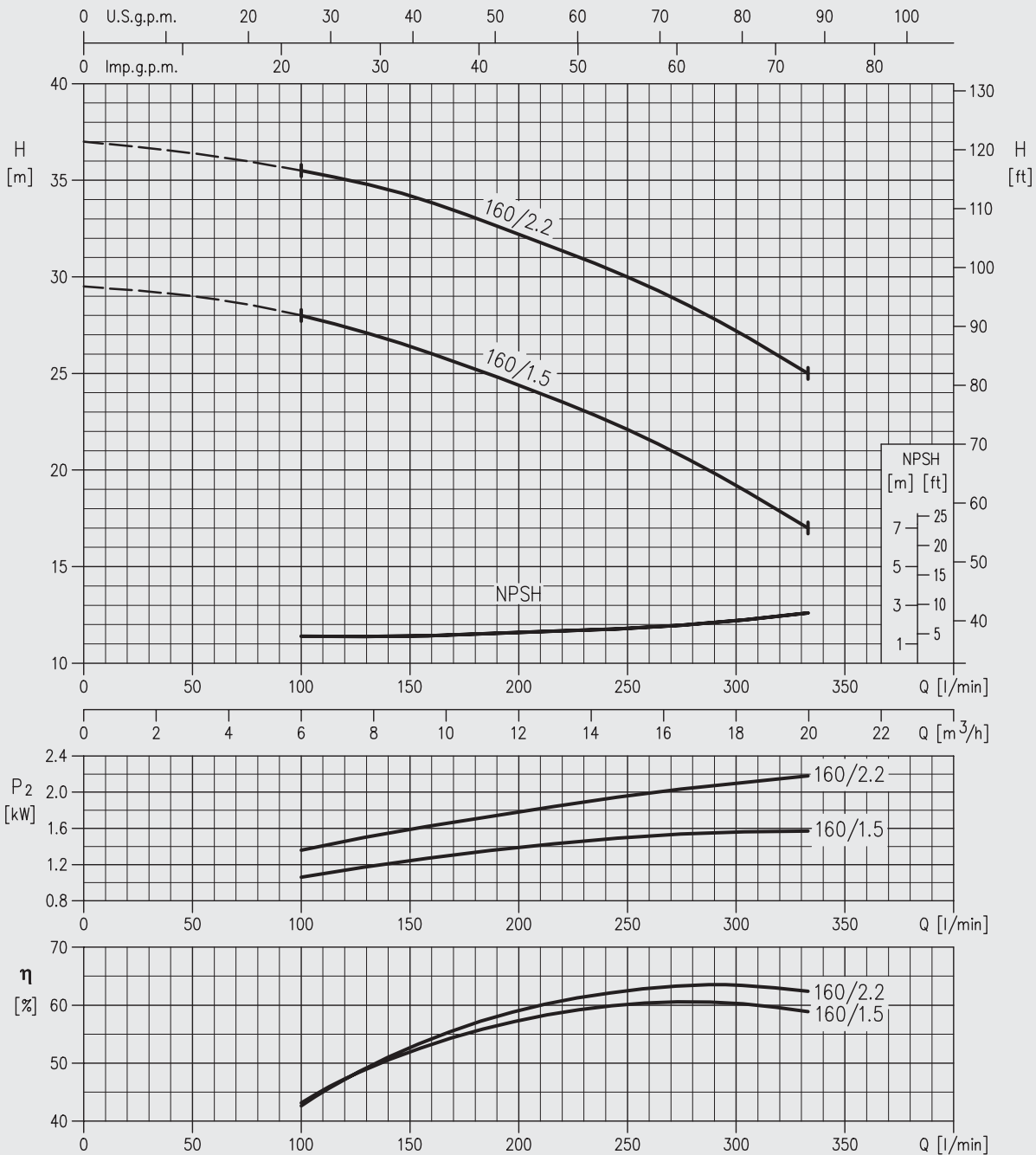

#### 32/200 SERIES

2900 min<sup>-1</sup>

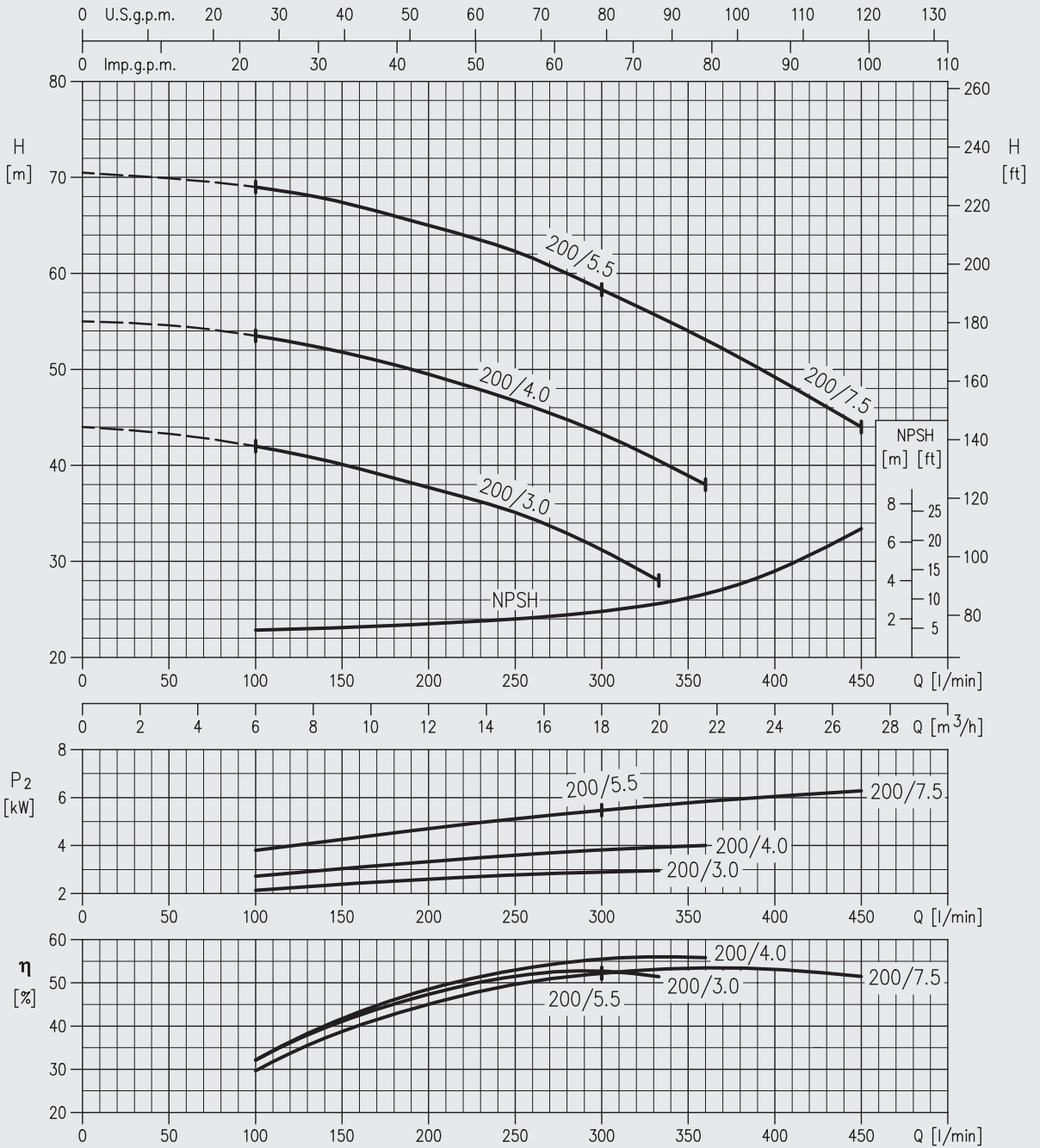



#### 40/125 SERIES

2900 min<sup>-1</sup>

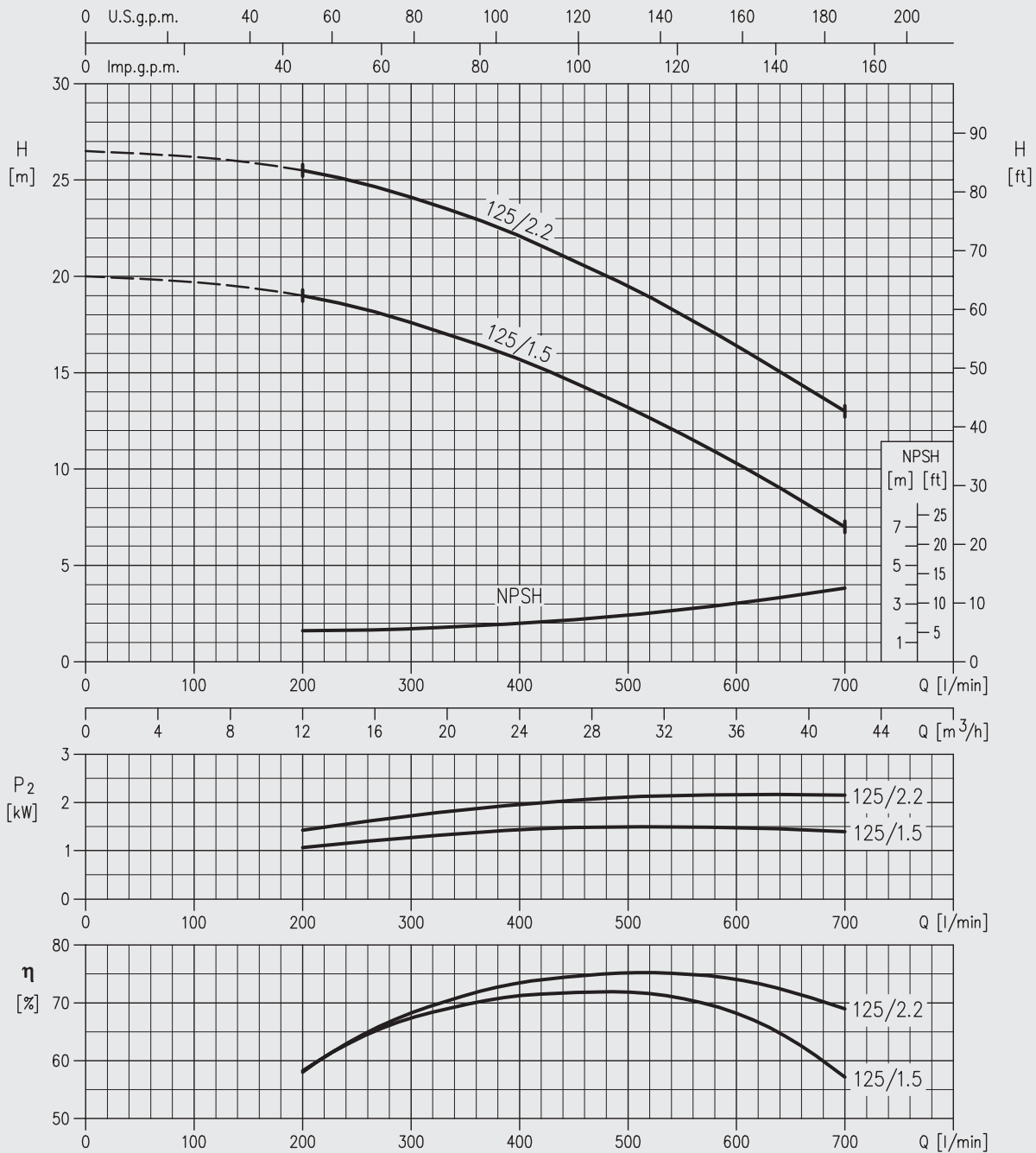

#### 40/160 SERIES

2900 min<sup>-1</sup>

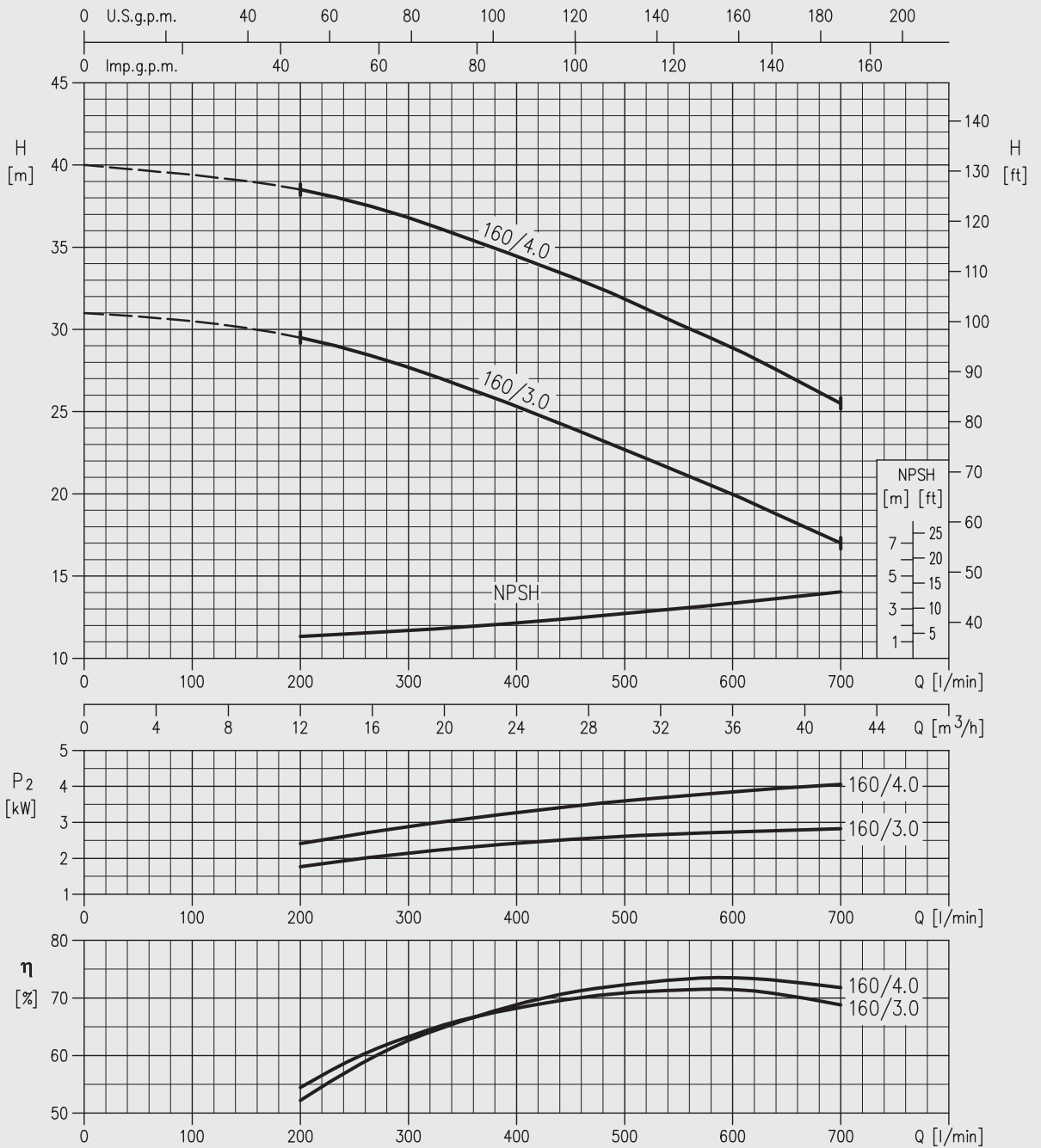

#### 40/200 SERIES

2900 min<sup>-1</sup>

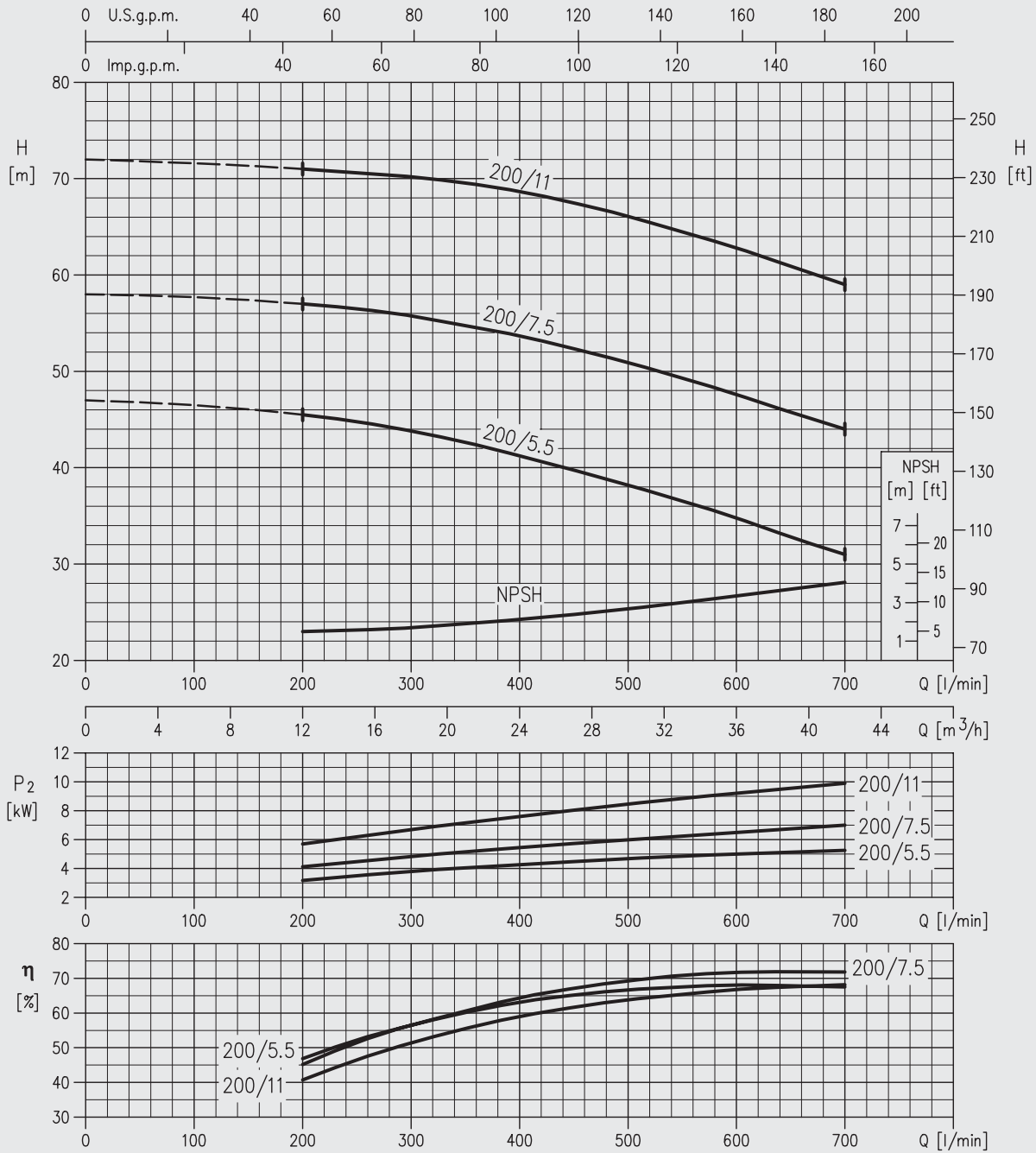

#### 50/125 SERIES

2900 min<sup>-1</sup>

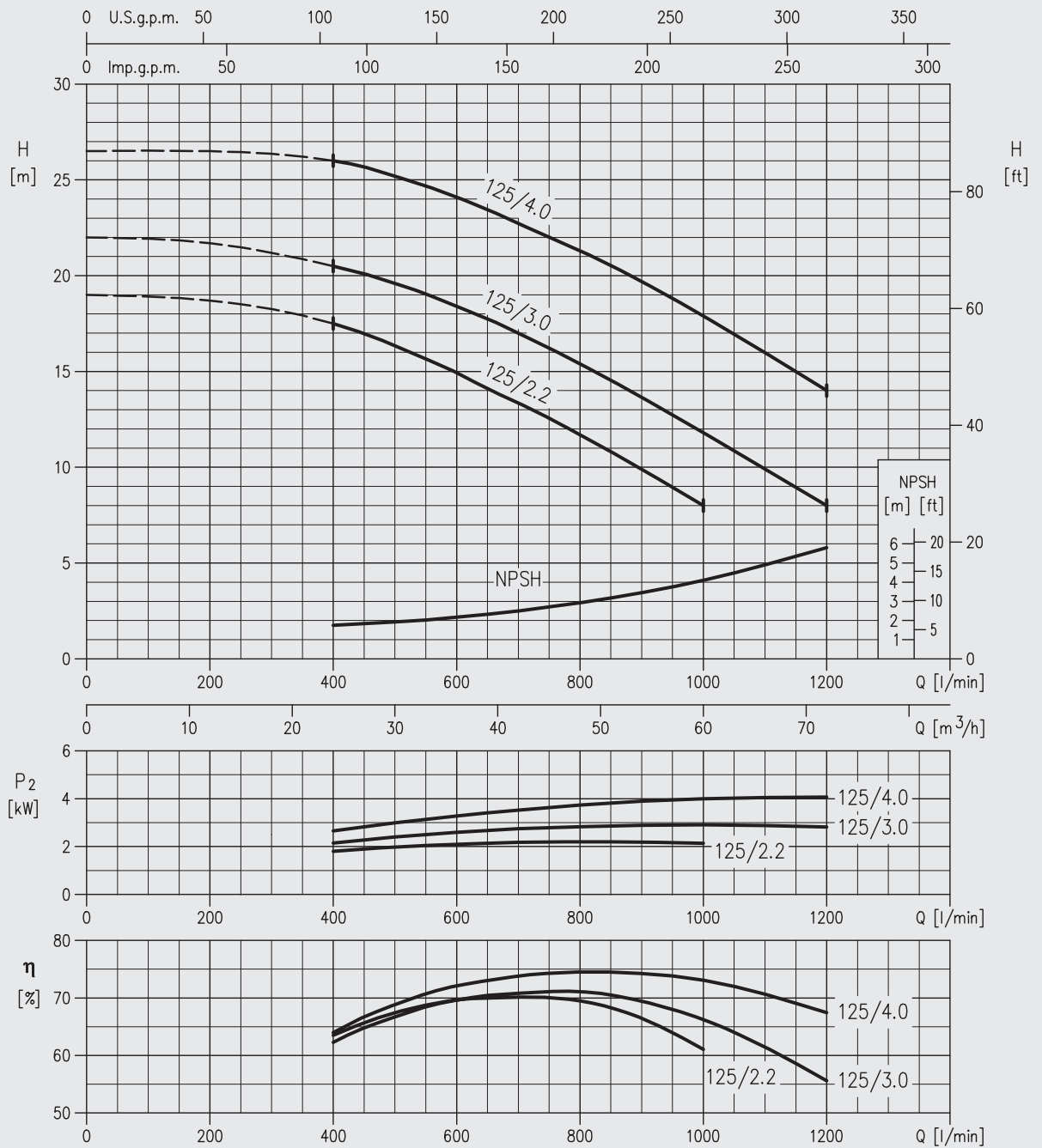

#### 50/160 SERIES

2900 min<sup>-1</sup>

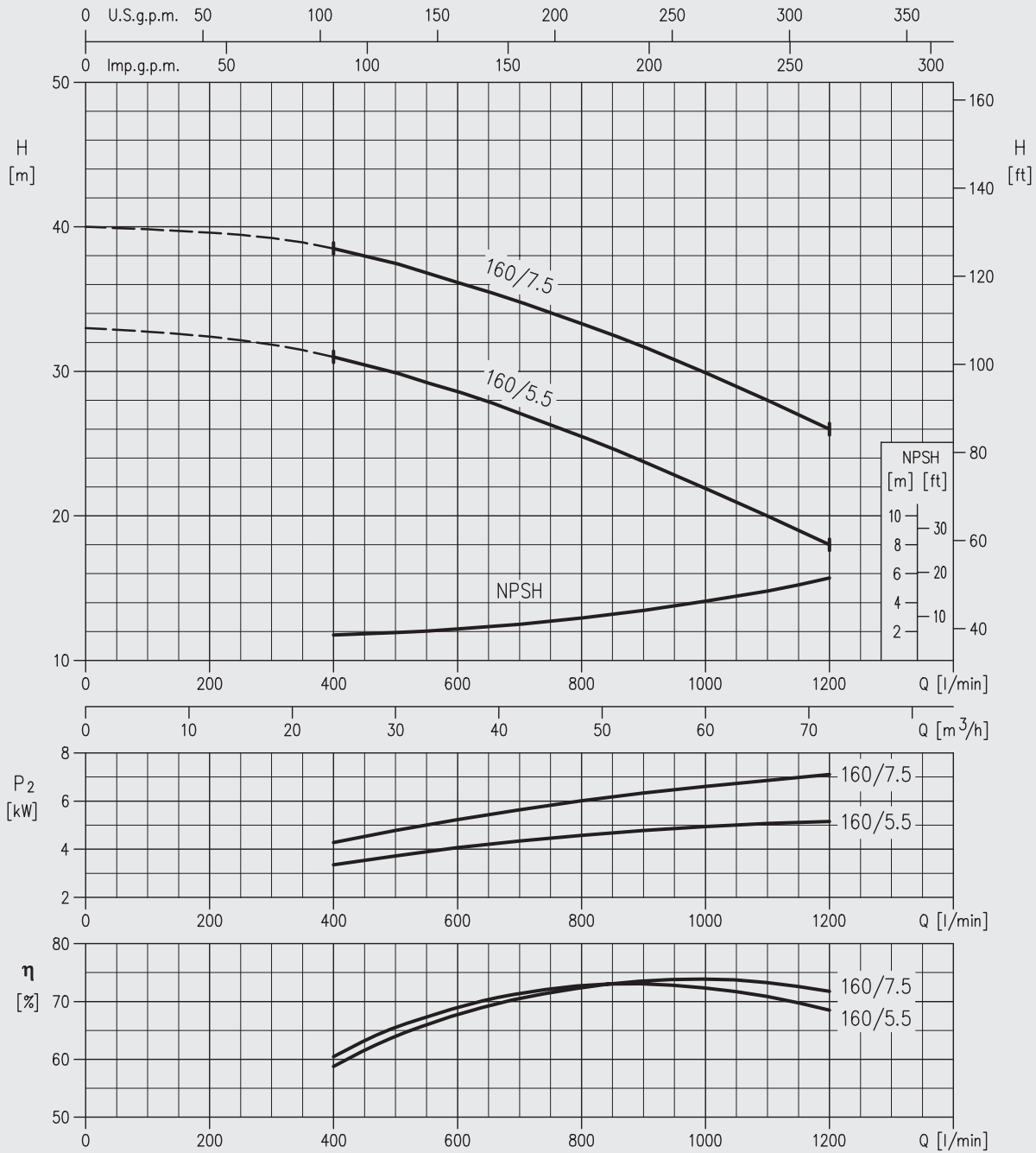

#### 50/200 SERIES

2900 min<sup>-1</sup>

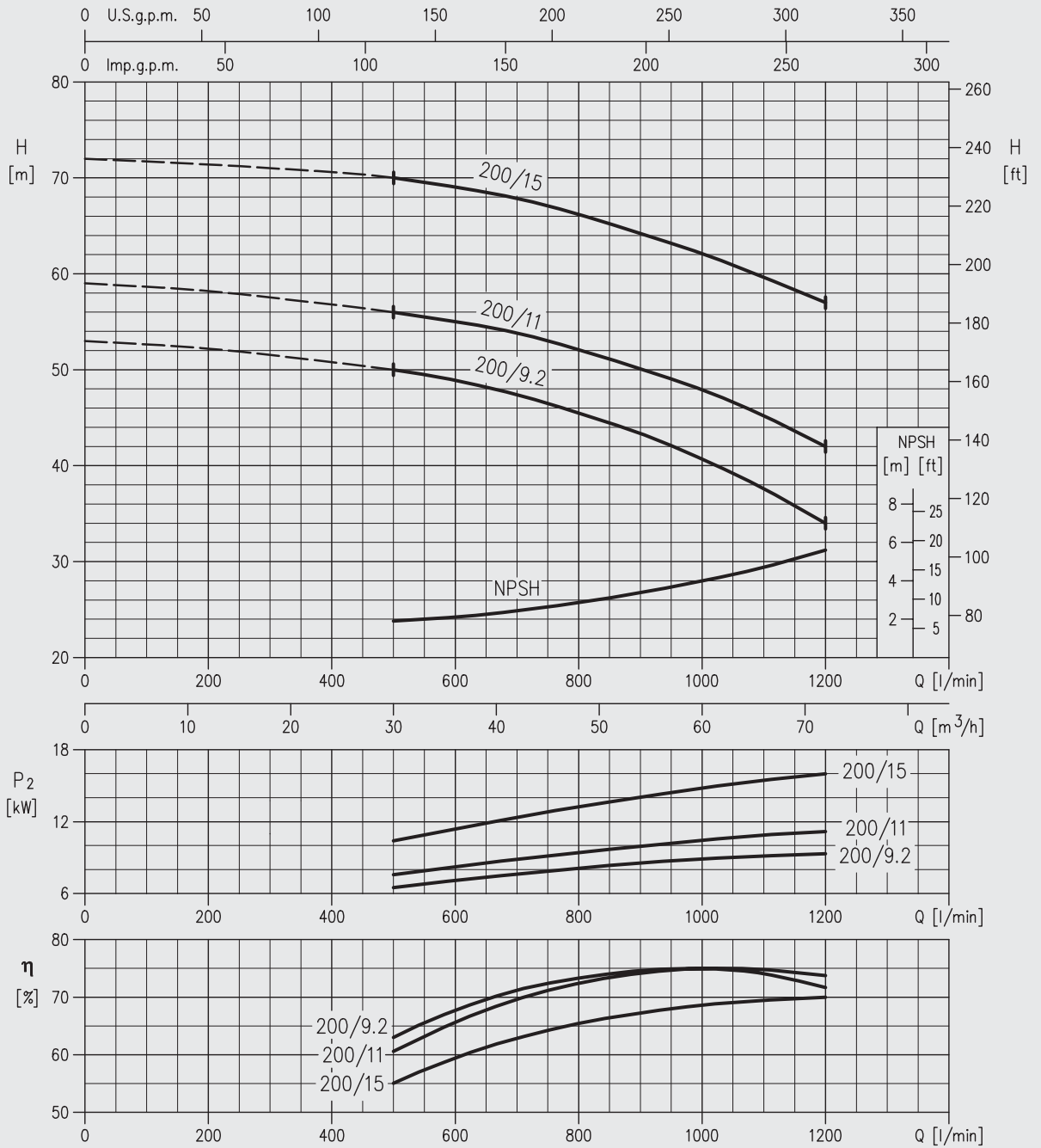

#### 65/125 SERIES

2900 min<sup>-1</sup>

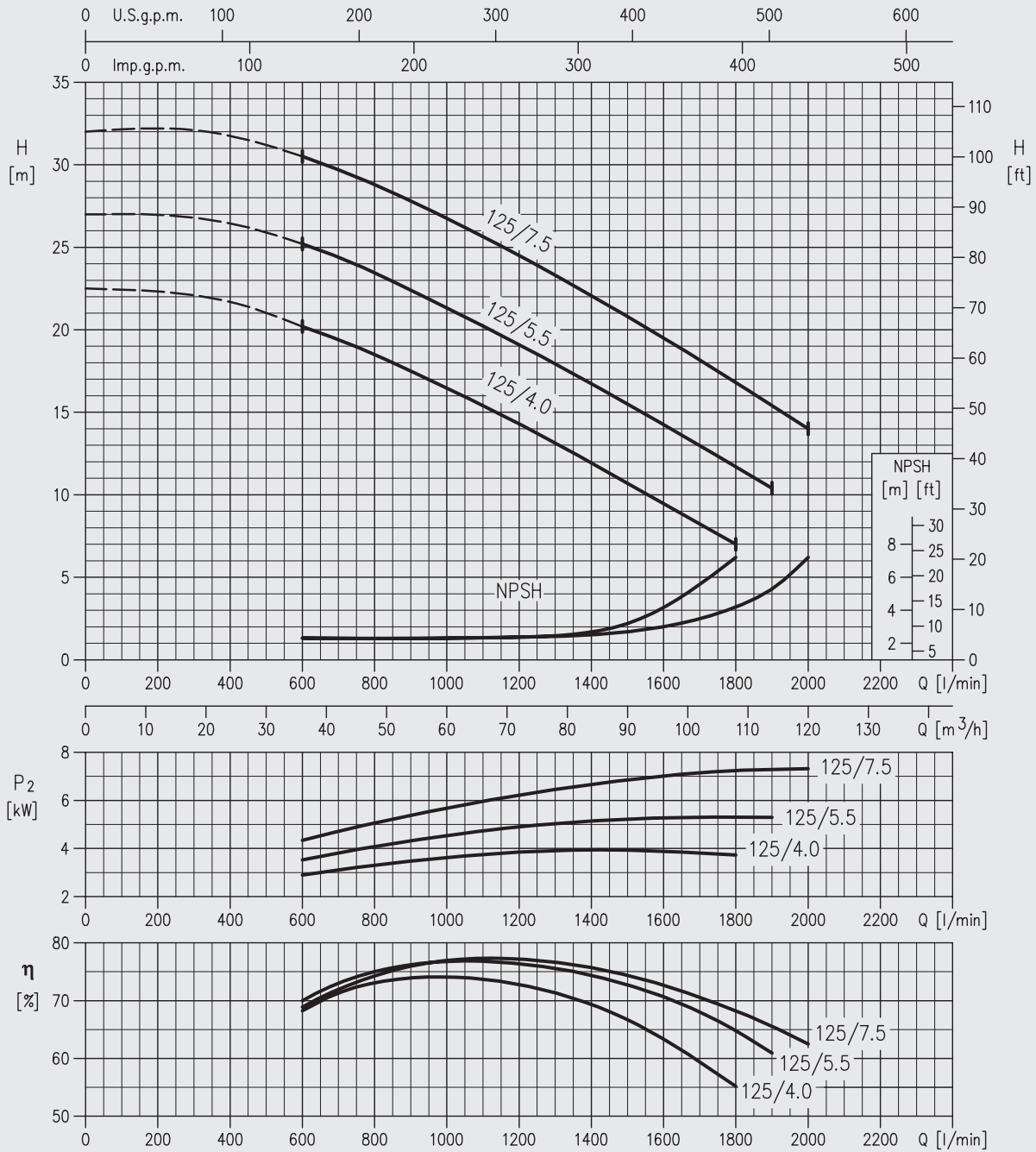

#### 65/160 SERIES

2900 min<sup>-1</sup>

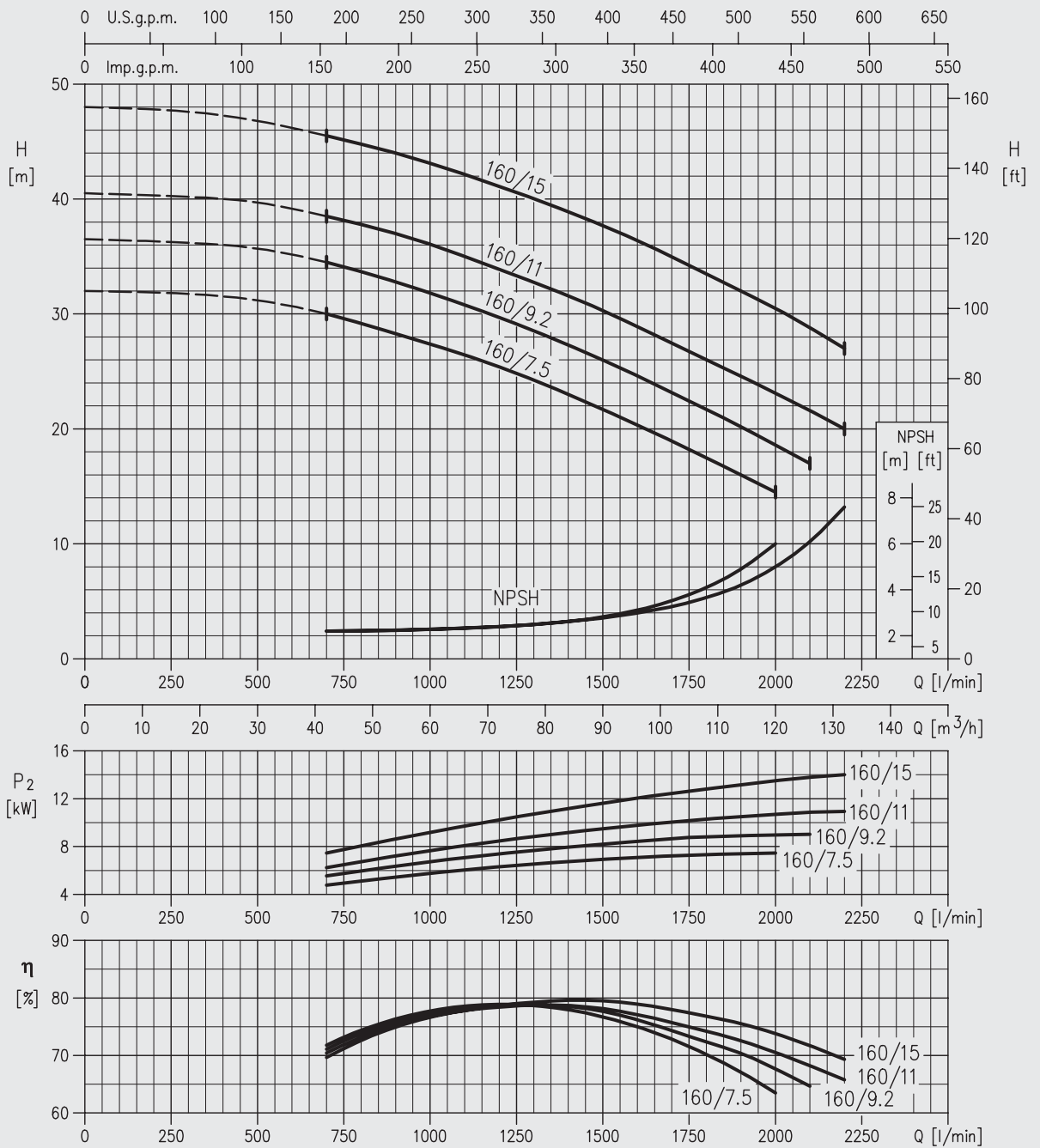



#### 65/200 SERIES

2900 min<sup>-1</sup>

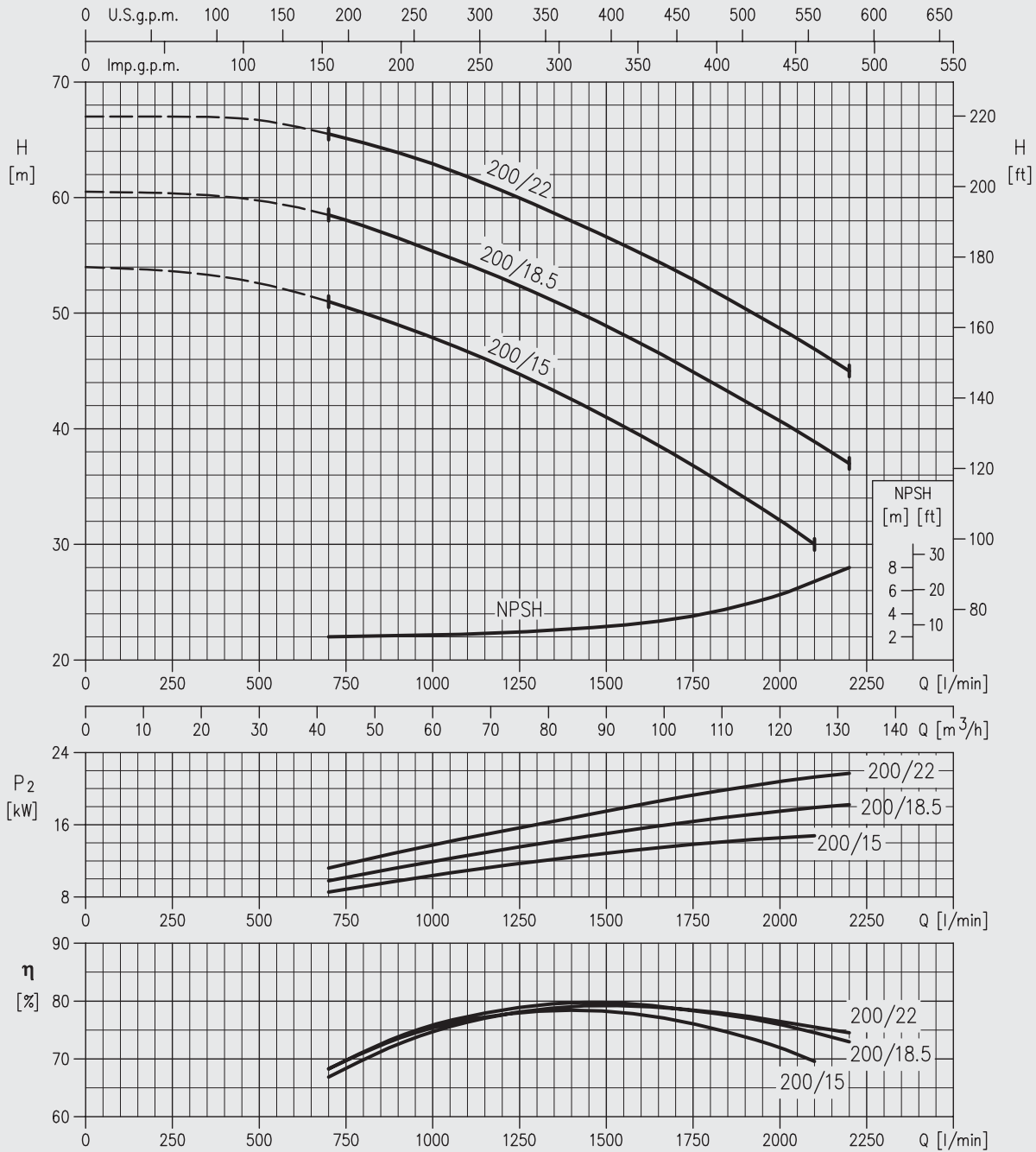

#### 32/125 SERIES

1450 min<sup>-1</sup>

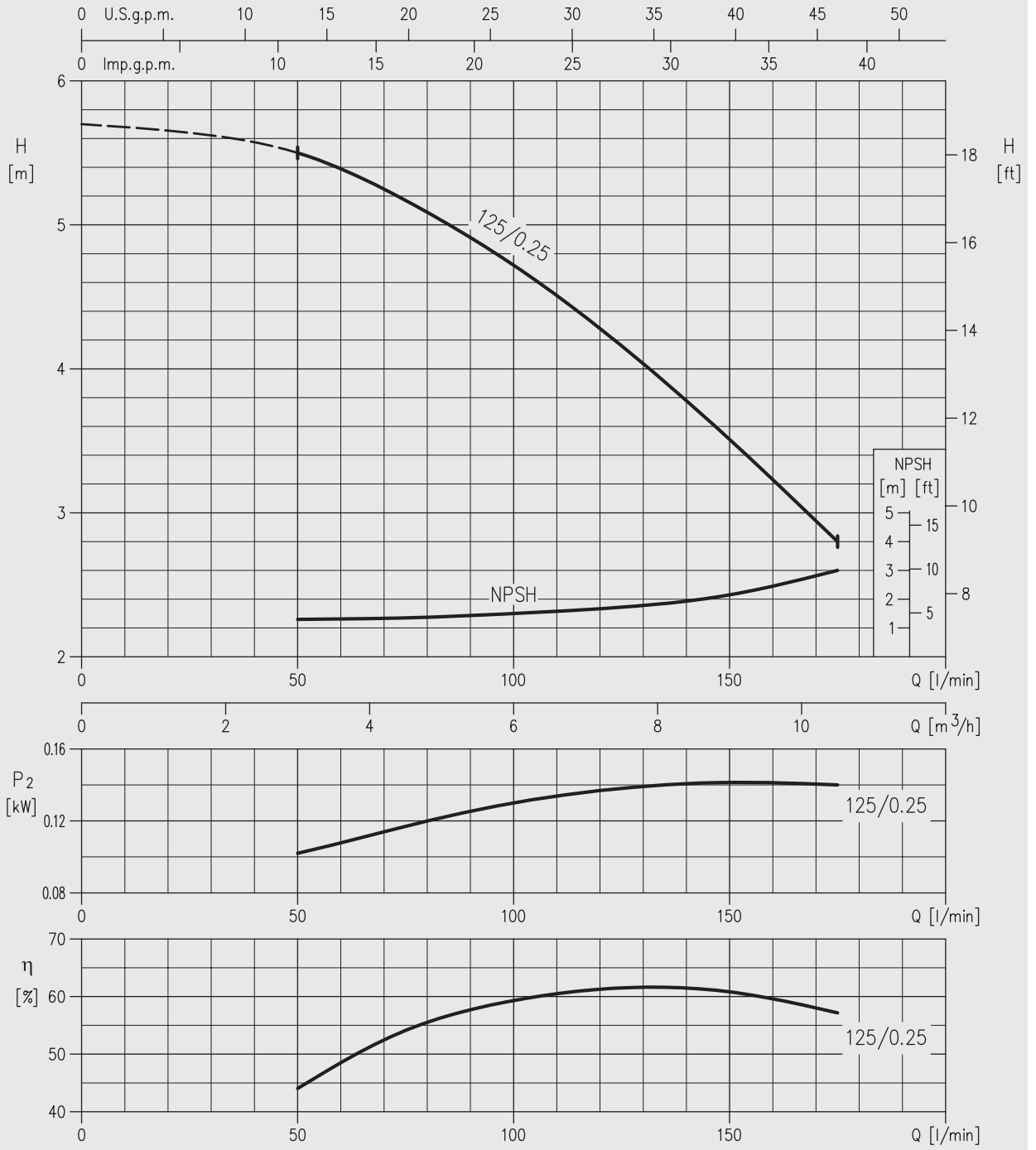

#### 32/160 SERIES

1450 min<sup>-1</sup>

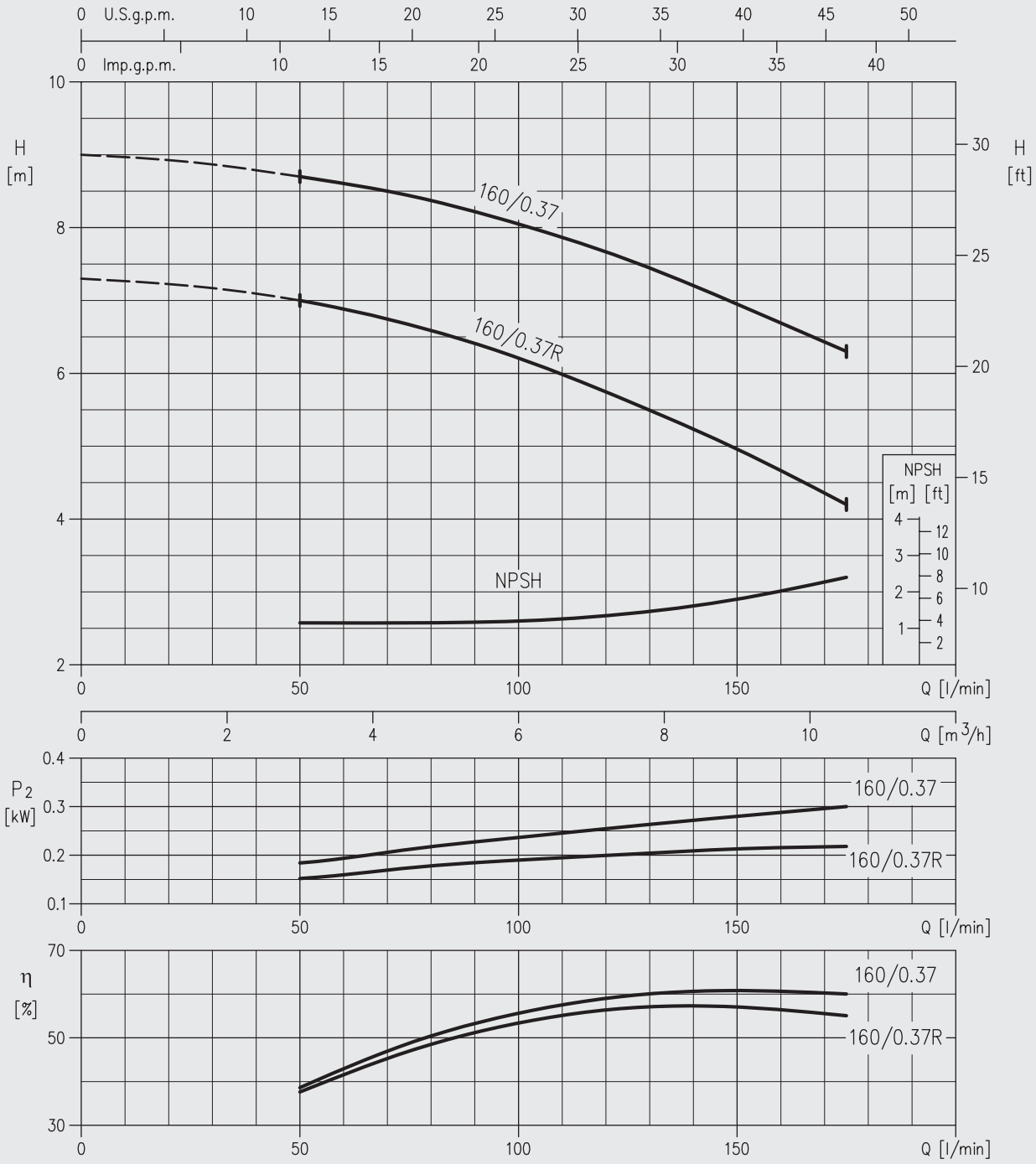

#### 32/200 SERIES

1450 min<sup>-1</sup>

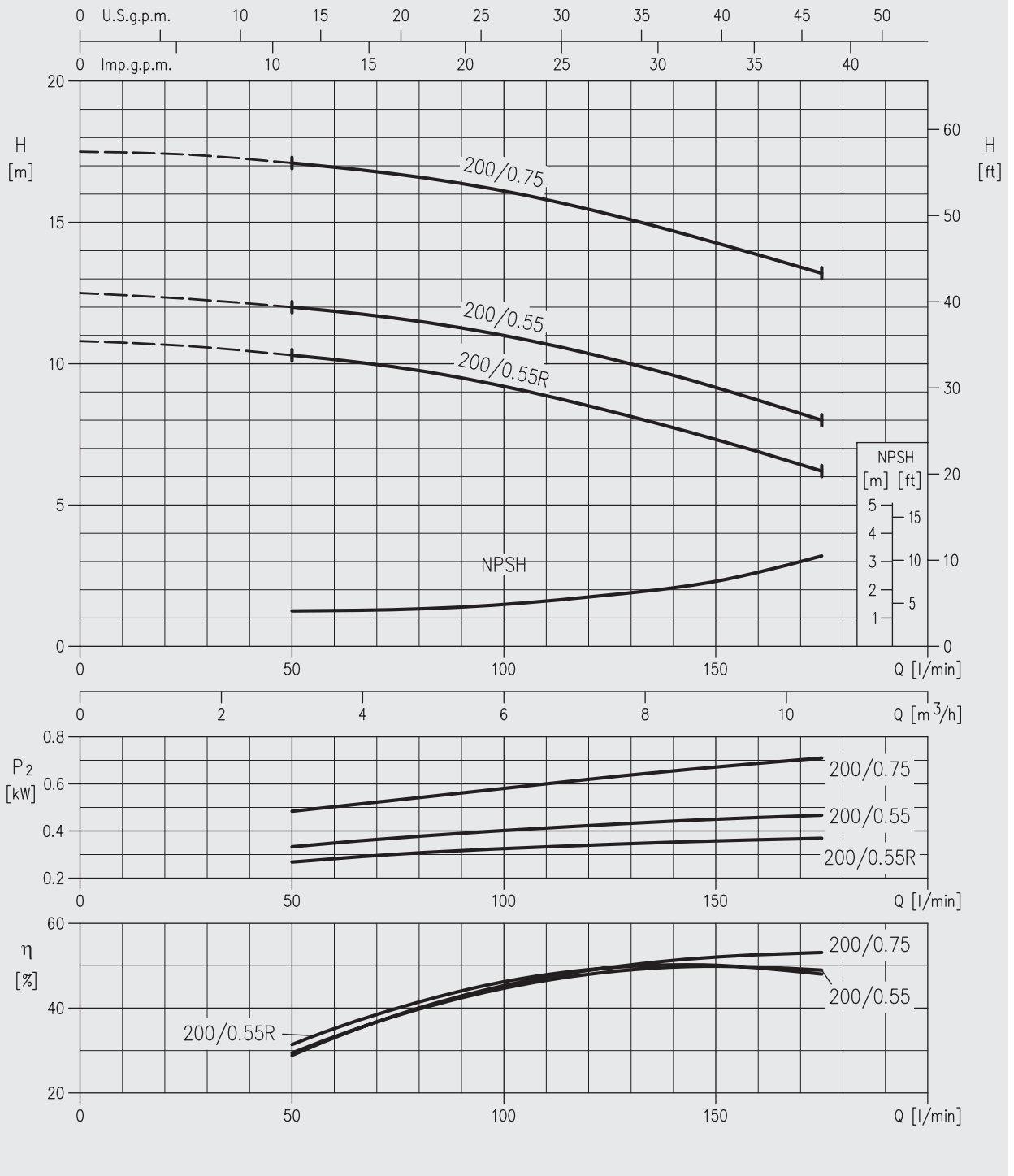

#### 40/125 SERIES

1450 min<sup>-1</sup>

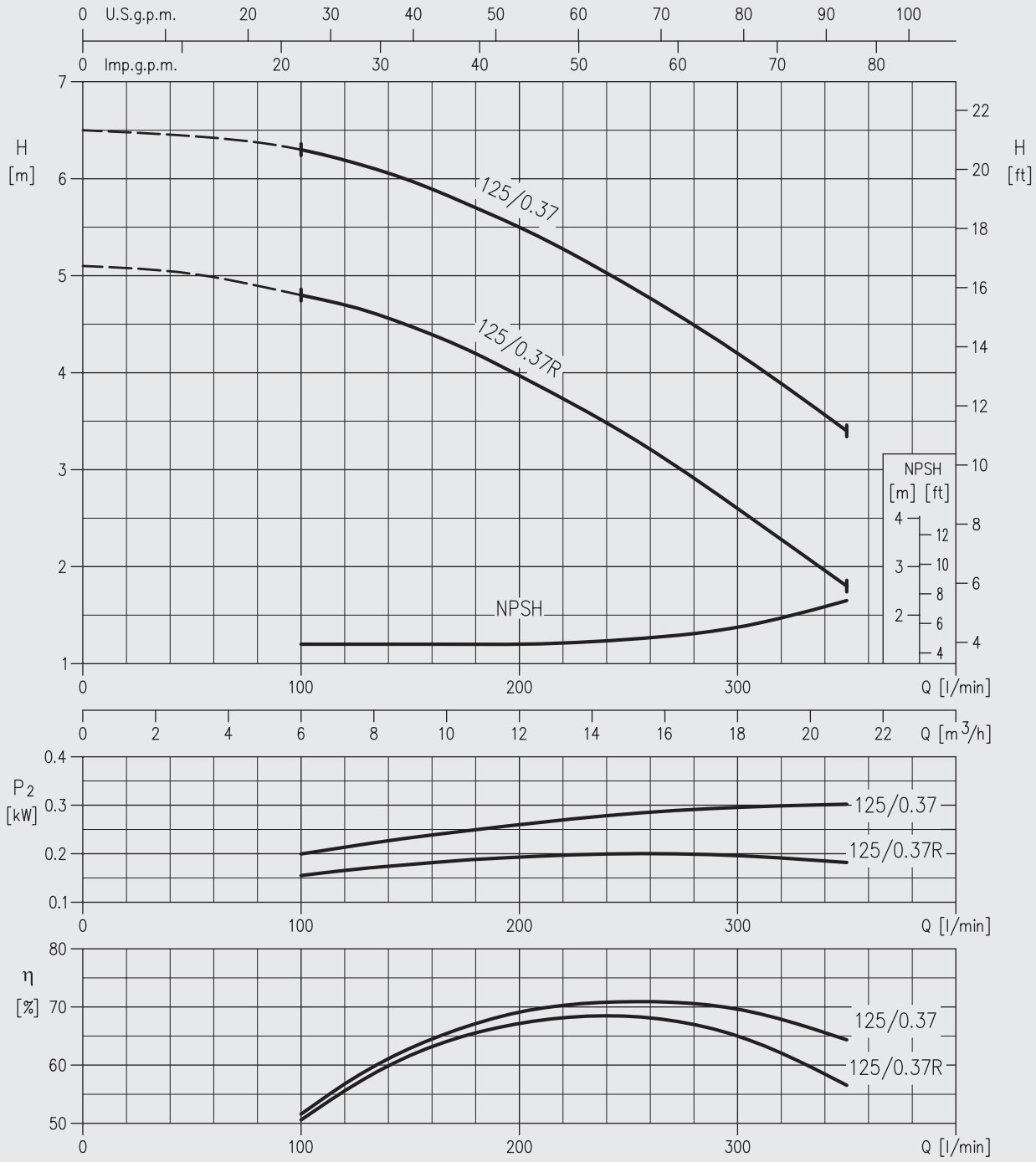

#### 40/160 SERIES

1450 min<sup>-1</sup>

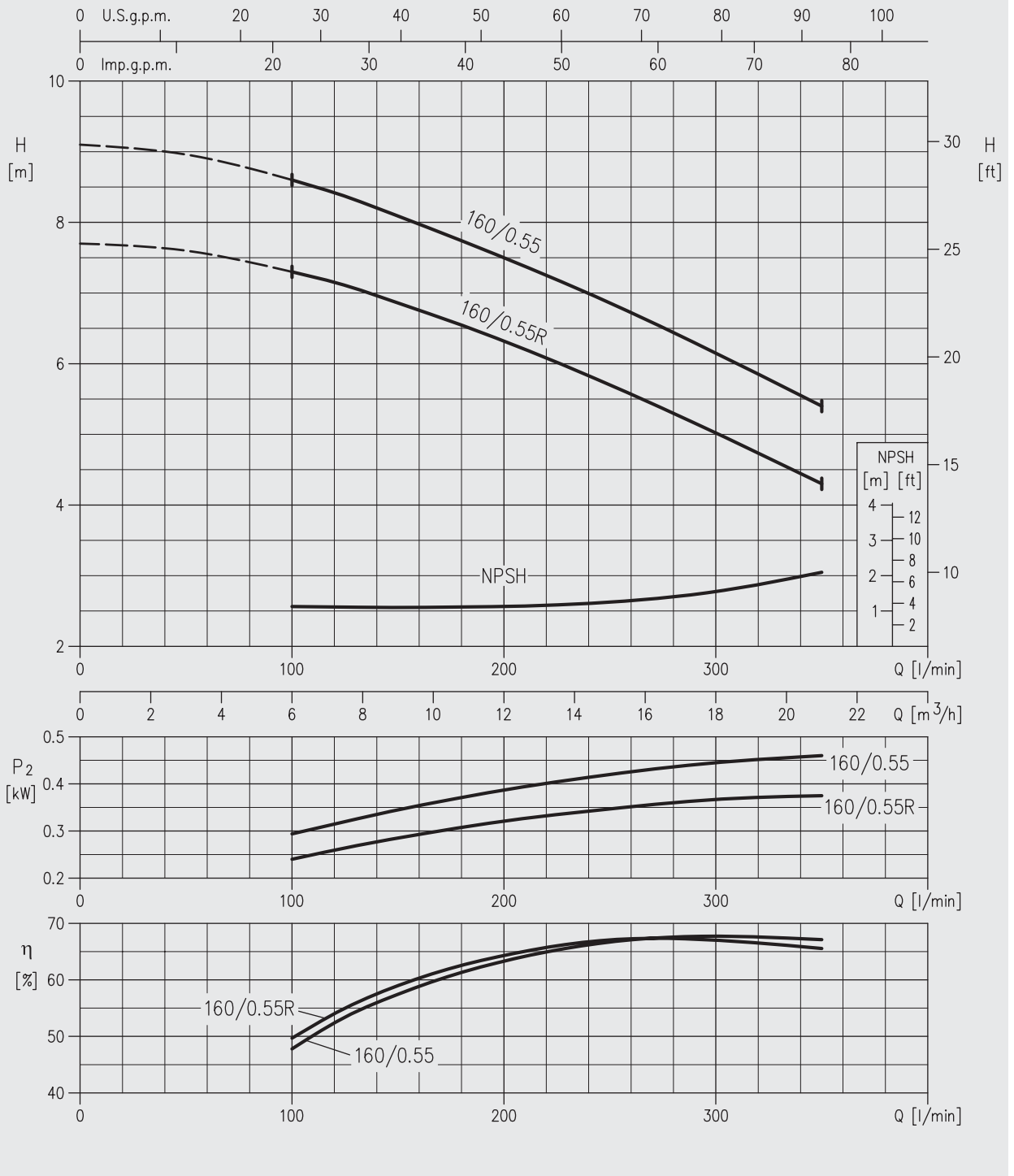

#### 40/200 SERIES

1450 min<sup>-1</sup>

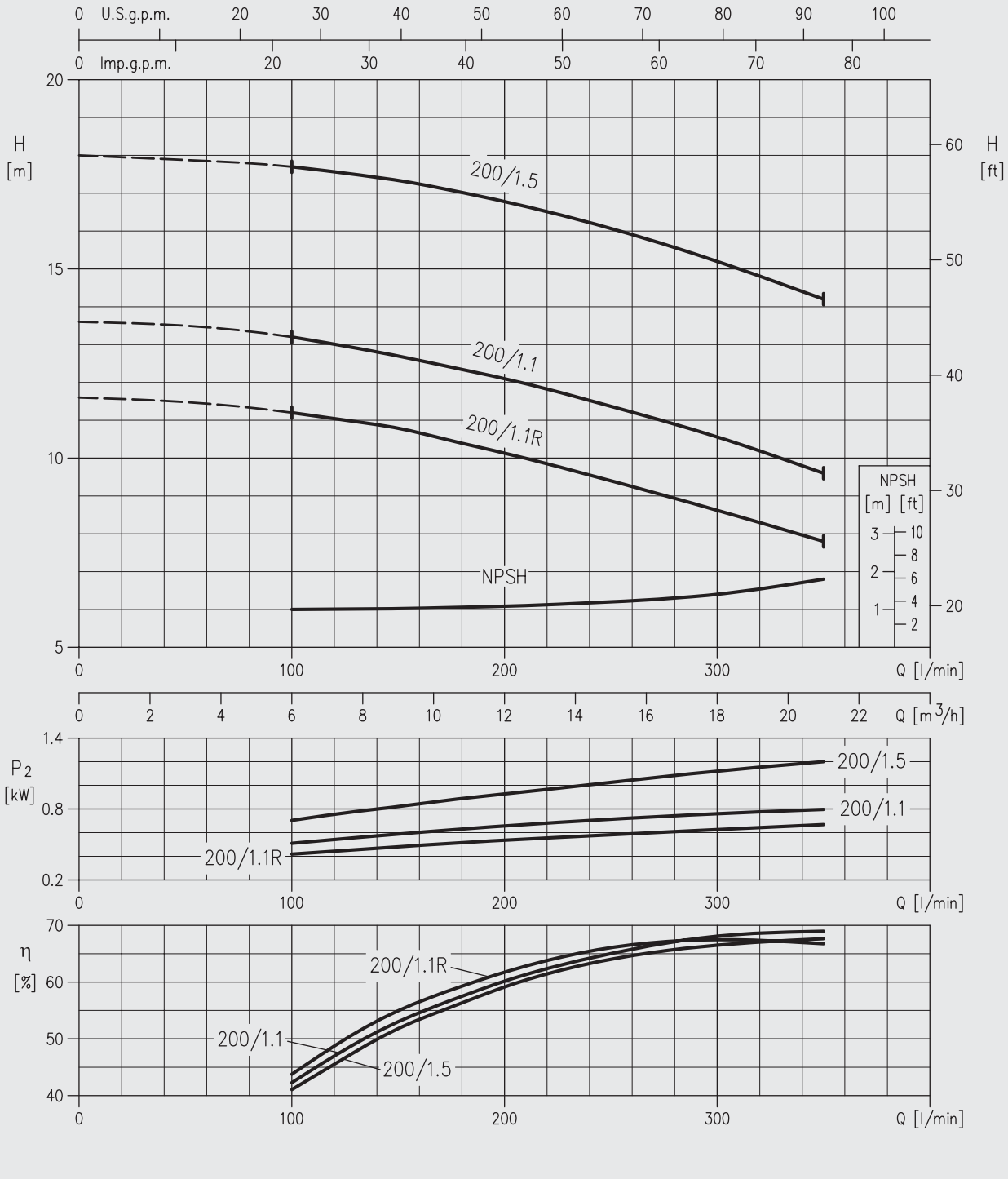

#### 50/125 SERIES

1450 min<sup>-1</sup>

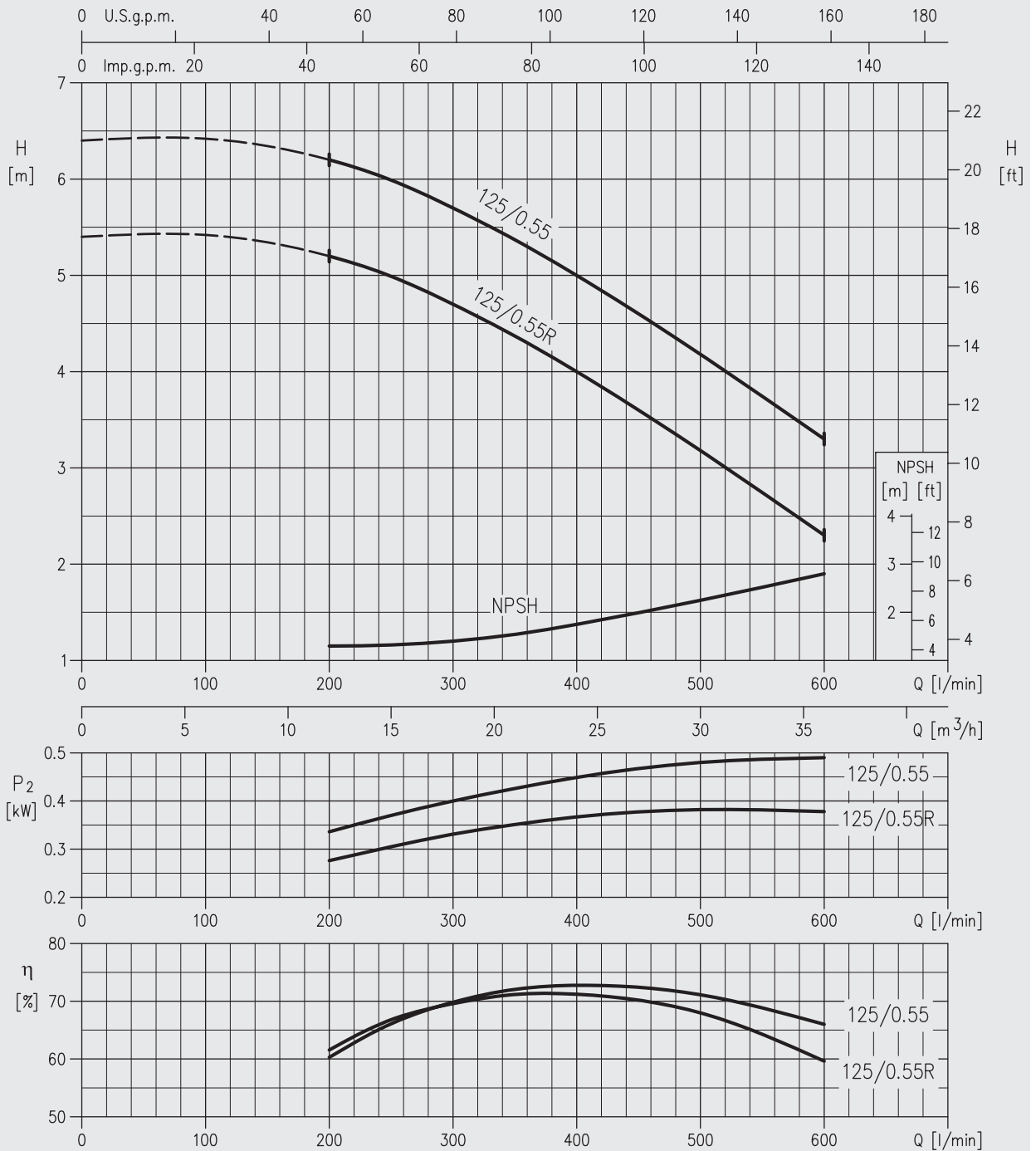



#### 50/160 SERIES

1450 min<sup>-1</sup>

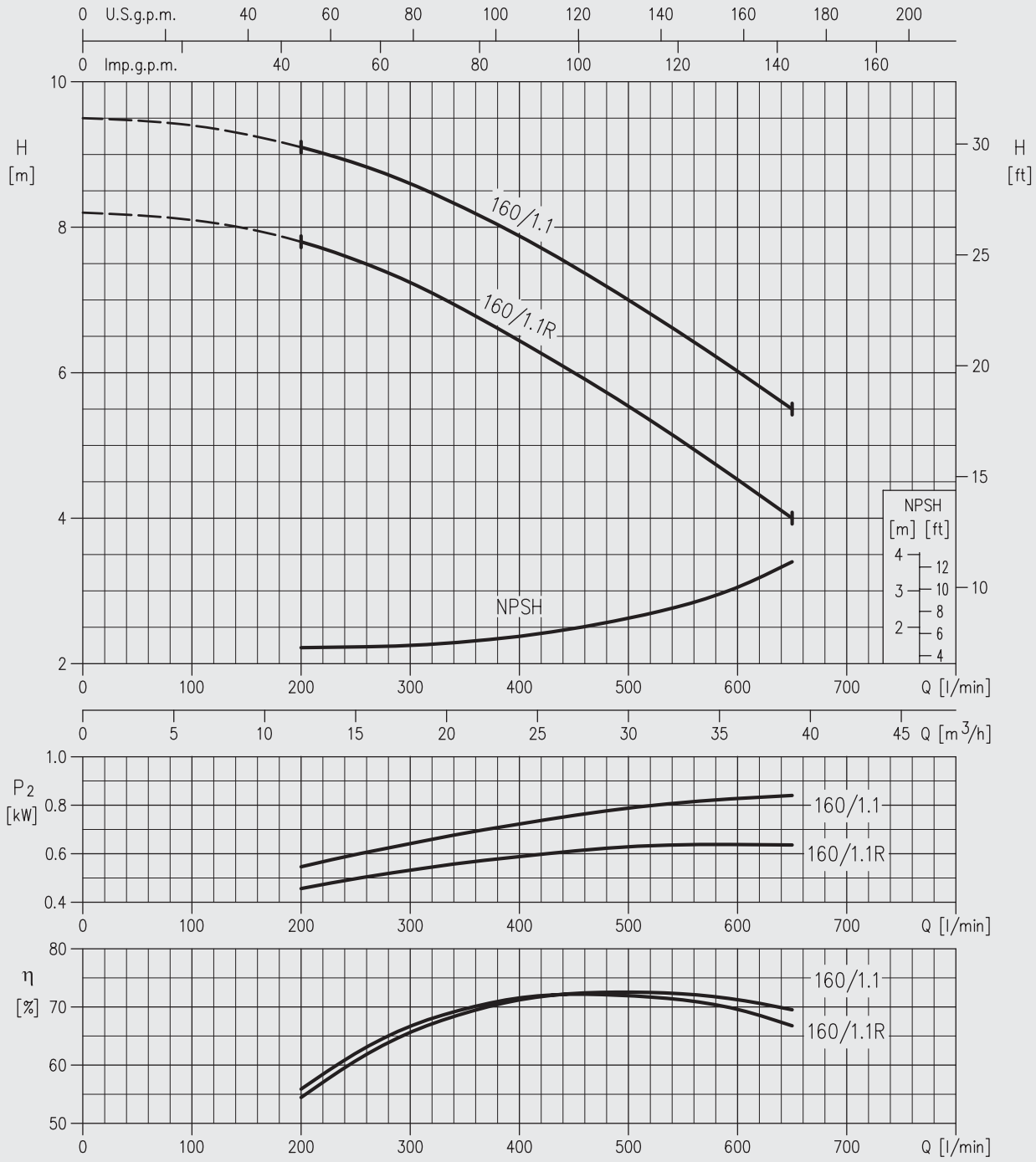

#### 50/200 SERIES

1450 min<sup>-1</sup>

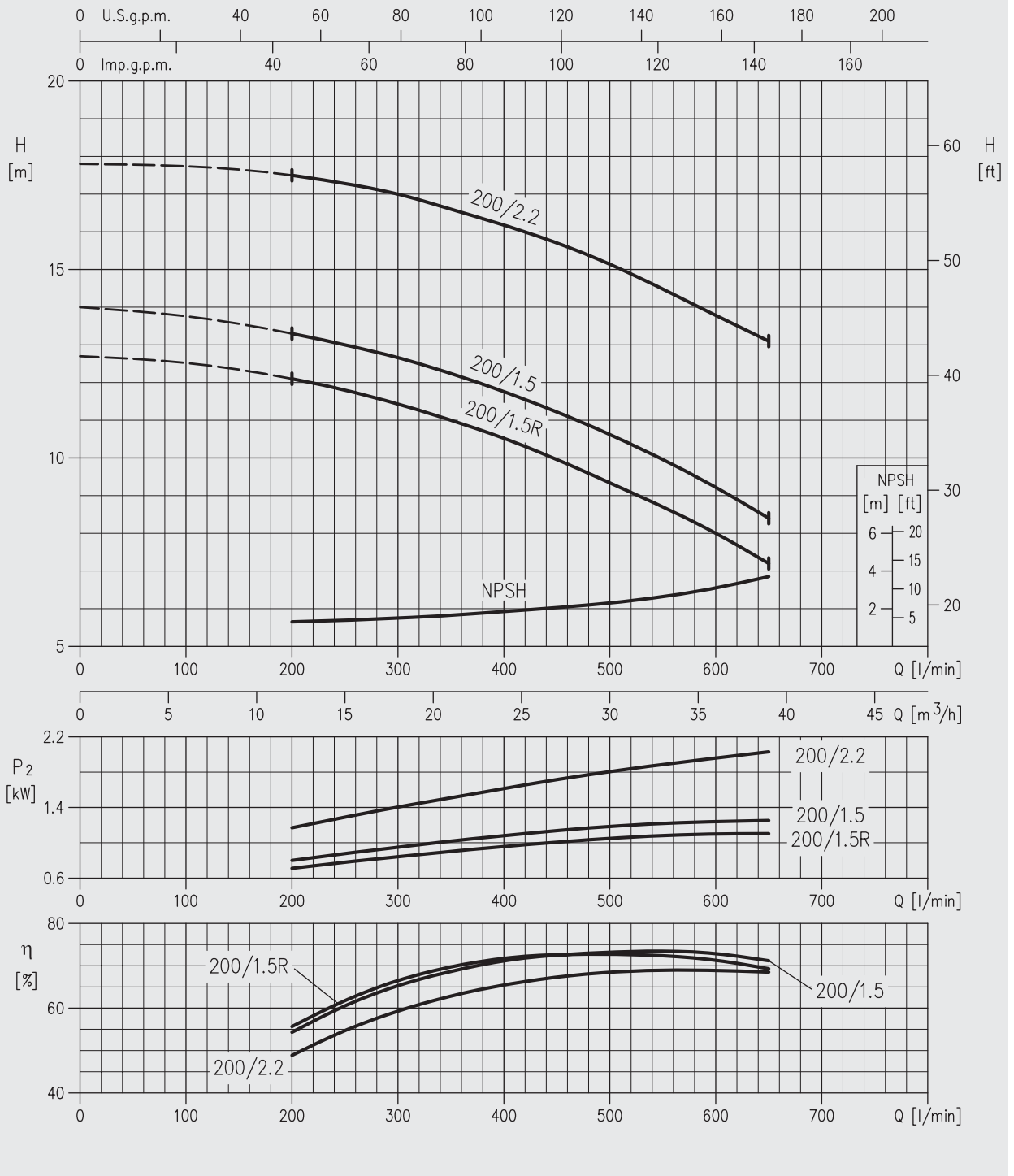

#### 65/125 SERIES

1450 min<sup>-1</sup>

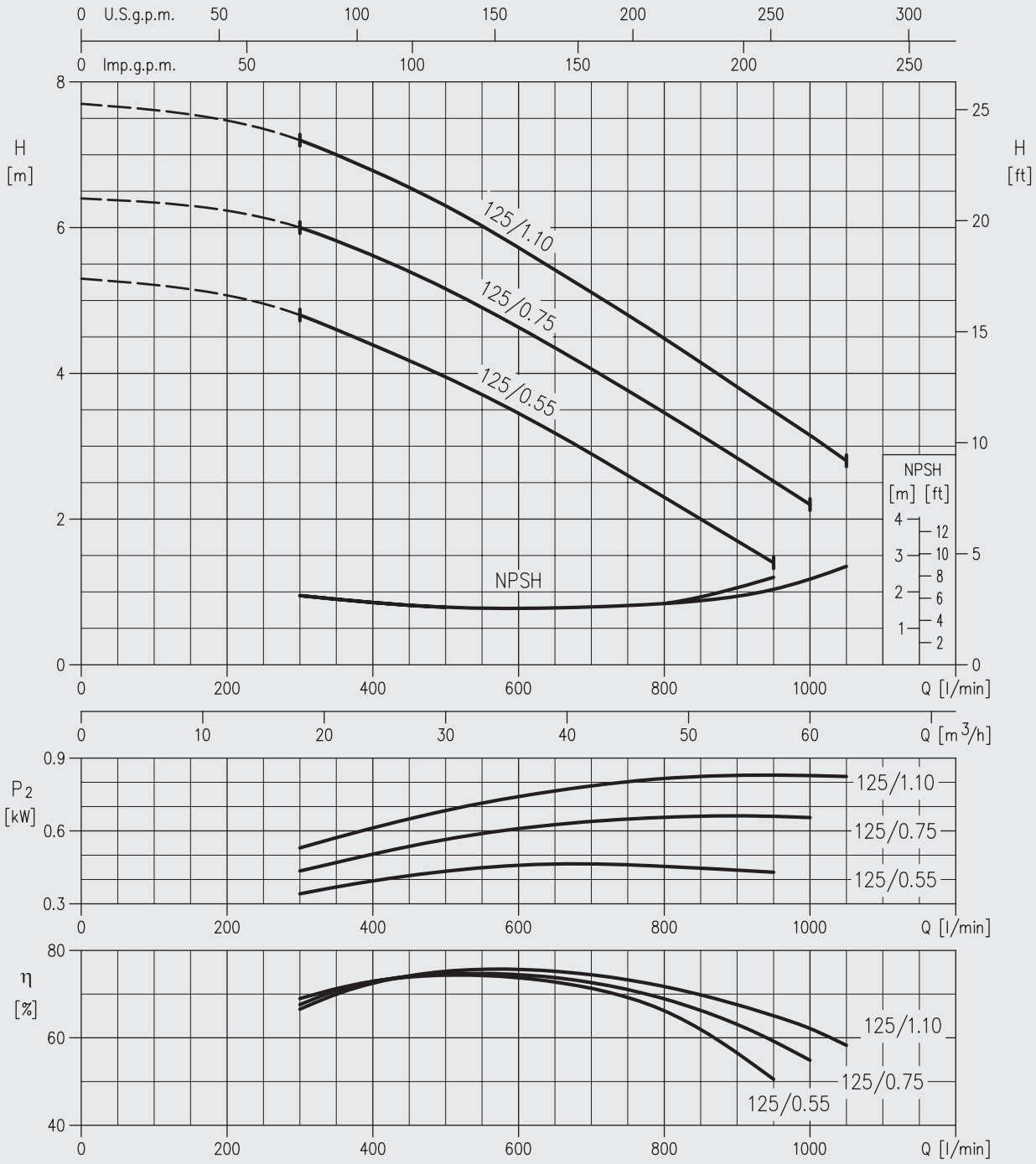

#### 65/160 SERIES

1450 min<sup>-1</sup>

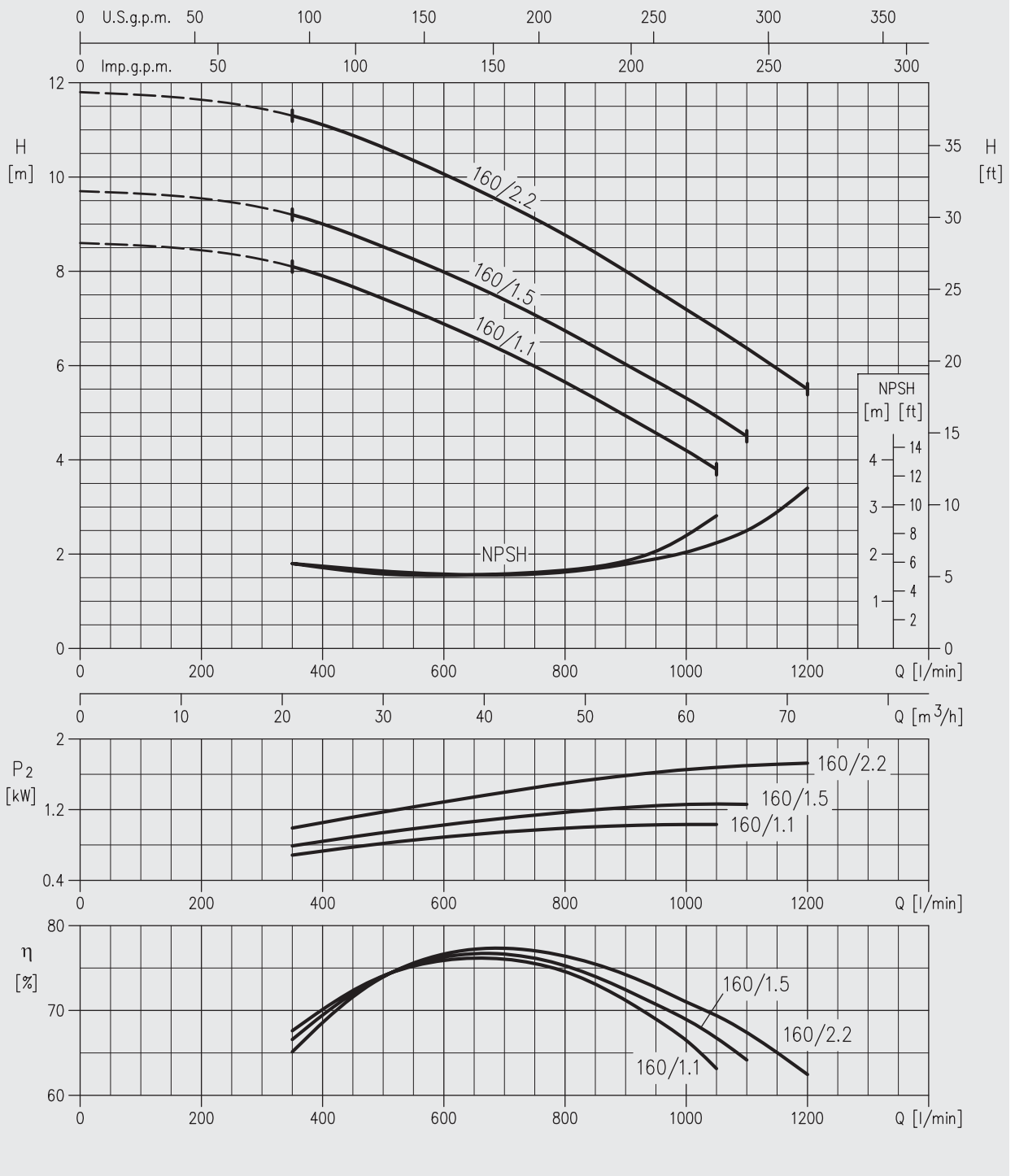

#### 65/200 SERIES

1450 min<sup>-1</sup>

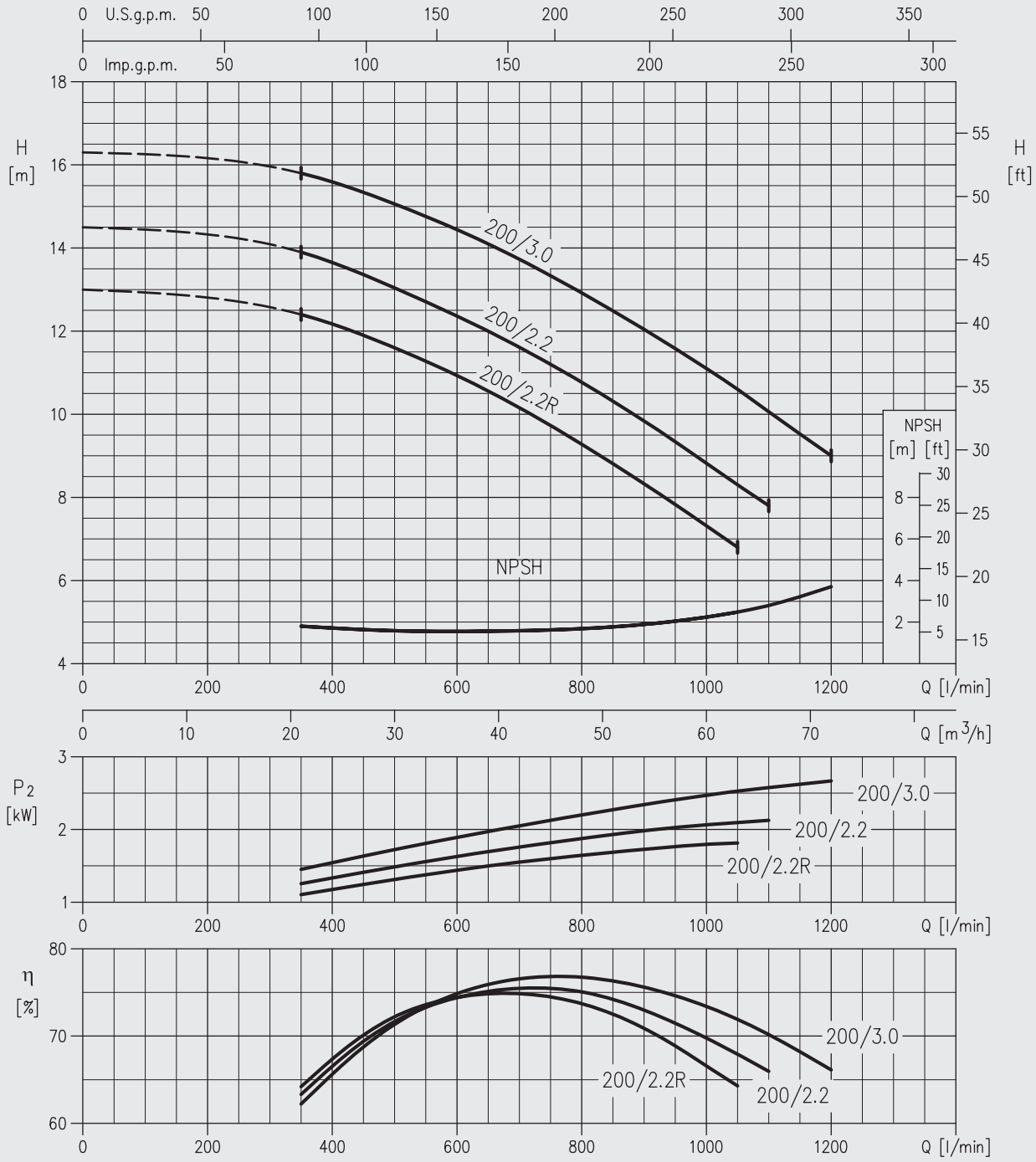

### 3M (3LM)

### EXPLODED VIEW AND LIST OF COMPONENT

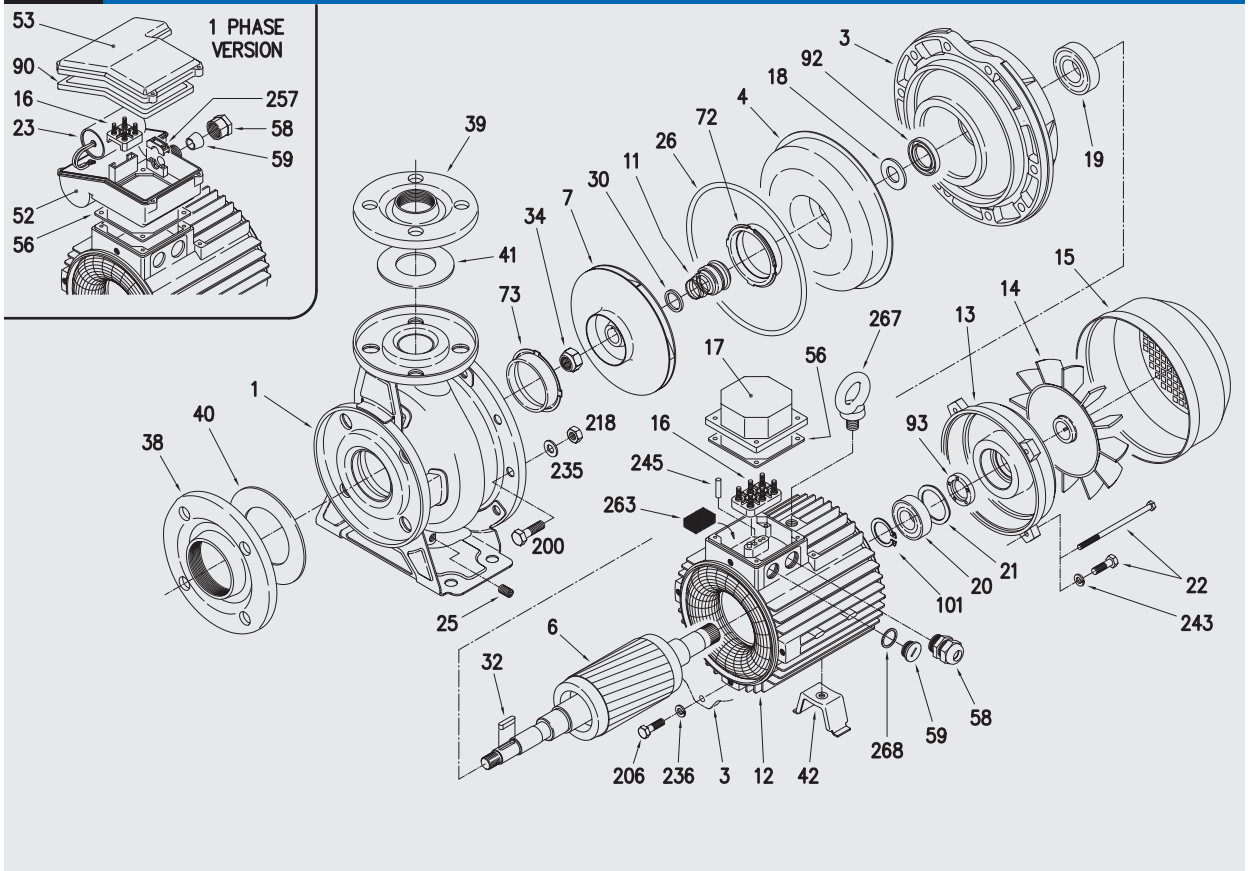

N°	PART NAME	MATERIAL		Q.TY	N°	PART NAME	MATERIAL		Q.TY
		3M	3LM				3M	3LM	
1	Casing	AISI 304	AISI 316L	1	20	Fan side ball bearing	-	-	1
3	Motor bracket	G20	G20	1	21	Adjusting ring	Steel C70	Steel C70	1
4	Casing cover	AISI 304	AISI 316L	1	22	Tie rod	Fe 42 Zinked	Fe 42 Zinked	4
6	Shaft with rotor (part in contact with liquid)	AISI 304	AISI 316L	1	25	Drain plug	AISI 316	AISI 316	1
7	Impeller	AISI 304	AISI 316L	1	26	O-ring [1]	NBR	FPM	1
11	Mechanical seal [1] - [2]	Carb/Ceram/NBR	SIC/SIC/FPM	1	30	Mechanical seal spacer	AISI 304	-	1
12	Motor frame with stator	-	-	1	32	Key	AISI 304	AISI 316	1
13	Motor cover	Aluminium	Aluminium	1	34	Impeller nut	AISI 304	AISI 316L	1
14	Fan	Polypropilene	Polypropilene	1	42	Motor support	Aluminium/ Carbon steel	Aluminium/ Carbon steel	1
15	Fan cover	Fe P04 Zinked	Fe P04 Zinked	1	56	Box gasket	NBR	NBR	1
16	Terminal box	-	-	1	58	Cable entry	-	-	1
17	Terminal box cover	Aluminium (three phase version)	Aluminium (three phase version)	1	72	Casing ring	AISI 304	AISI 316L	1
18	Splash ring	NBR	-	1	73	Casing ring	AISI 304	AISI 316L	1
19	Pump side ball bearing	-	-	1	92	Lip seal	-	-	1
					93	Lip seal	-	-	1
					200	Screw	Stainless steel A2 UNI7323	Stainless steel A2 UNI7323	8-12

[1] FPM for 3MH-3MHS version

[2] See constructions mechanical seal pages 56/57

### 3S (3LS)

### EXPLODED VIEW AND LIST OF COMPONENT

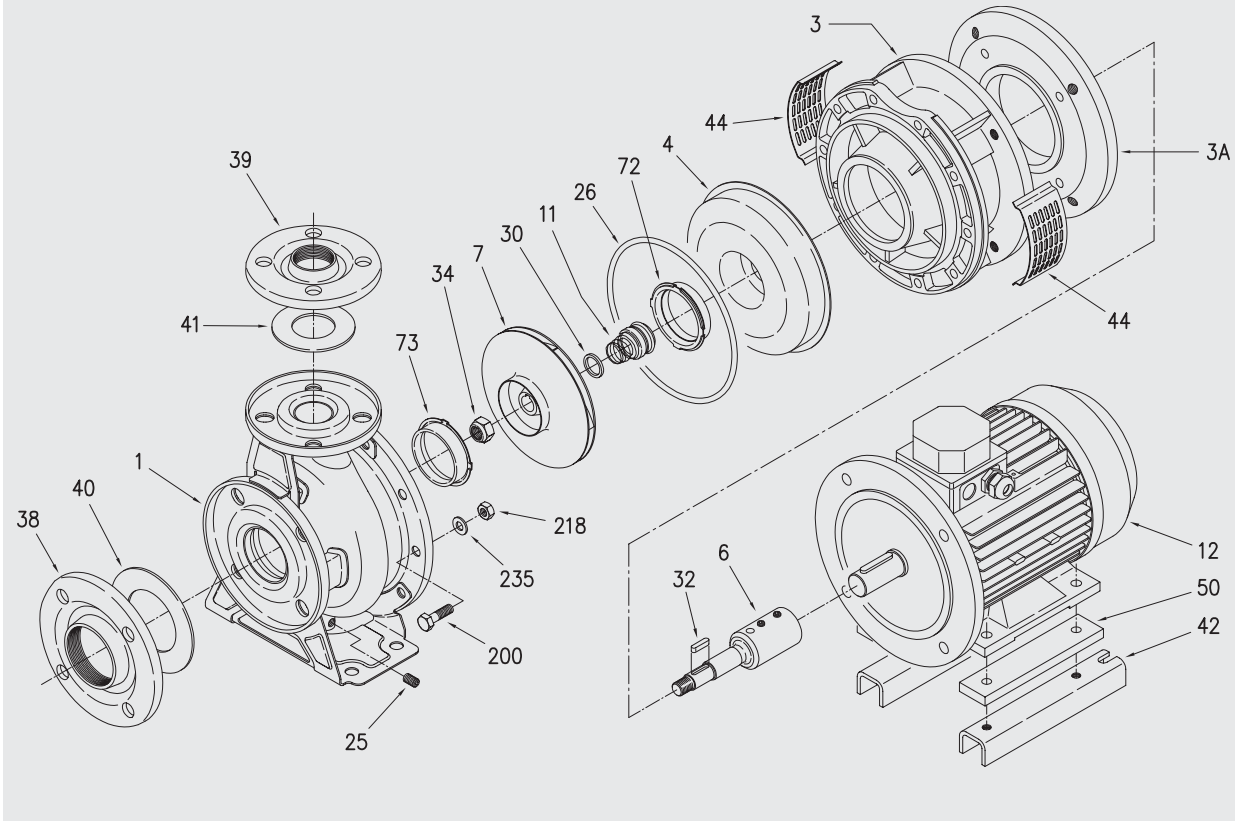

N°	PART NAME	MATERIAL		Q.TY	N°	PART NAME	MATERIAL		Q.TY
		3S	3LS				3S	3LS	
1	Casing	AISI 304	AISI 316L	1	30	Mechanical seal spacer	AISI 304	-	1
3	Motor bracket	G20	G20	1	32	Key	AISI 304	AISI 316	1
4	Casing cover	AISI 304	AISI 316L	1	34	Impeller nut	AISI 304	AISI 316L	1
6	Extension shaft (part in contact with liquid)	AISI 304	AISI 316L	1	42	Motor support	Aluminium	Aluminium	1
7	Impeller	AISI 304	AISI 316L	1	44	Protection	AISI 304	AISI 304	1
11	Mechanical seal [1] - [2]	Carb/Ceram/NBR	SiC/SiC/FPM	1	72	Casing ring	AISI 304	AISI 316L	1
12	Motor frame	-	-	1	73	Casing ring	AISI 304	AISI 316L	1
25	Drain plug	AISI 316	AISI 316	1	200	Screw	Stainless steel A2 UNI7323	Stainless steel A2 UNI7323	8-12
26	O-ring [1]	NBR	FPM	1	206	Flange screw	Zinc steel UNI5739	Zinc steel UNI5739	4

[1] FPM for 3SH-3SHS version

[2] See constructions mechanical seal pages 56/57

### 3P (3LP)

### EXPLODED VIEW AND LIST OF COMPONENT

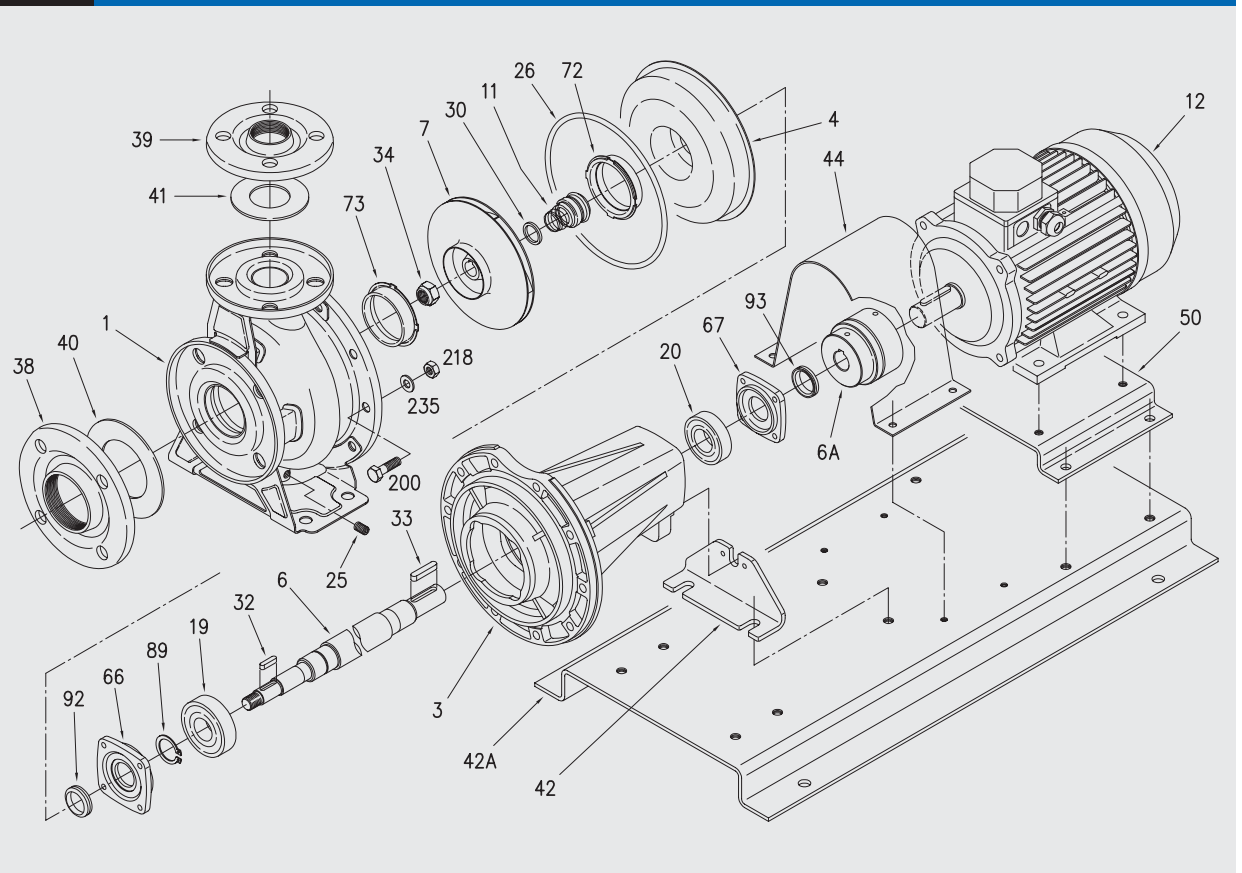

N°	PART NAME	MATERIAL		Q.TY	N°	PART NAME	MATERIAL		Q.TY
		3P	3LP				3P	3LP	
1	Casing	AISI 304	AISI 316L	1	34	Impeller nut	AISI 304	AISI 316L	1
3	Motor bracket	G25	G25	1	42	Motor support	Fe 37	Fe 37	1
4	Casing cover	AISI 304	AISI 316L	1	44	Protection	Fe 37	Fe 37	1
6	Shaft (part in contact with liquid)	AISI 304	AISI 316L	1	50	Foot	Fe 37	Fe 37	1
7	Impeller	AISI 304	AISI 316L	1	58	Cable entry	-	-	1
11	Mechanical seal [1] - [2]	Carb/Ceram/NBR	SIC/SIC/FPM	1	66	Impeller side bearing cover	G25	G25	1
12	Motor frame with stator	-	-	1	67	Extension shaft side bearing cover	G25	G25	1
19	Pump side ball bearing	-	-	1	72	Casing ring	AISI 304	AISI 316L	1
20	Fan side ball bearing	-	-	1	73	Casing ring	AISI 304	AISI 316L	1
25	Drain plug	AISI 316	AISI 316	1	92	Lip seal	-	-	1
26	O-ring [1]	NBR	FPM	1	93	Lip seal	-	-	1
30	Mechanical seal spacer	AISI 304	-	1	130	Flexible coupling	G25	G25	1
32	Key	AISI 304	AISI 316	1	142	Base	Fe 37	Fe 37	1
33	Key	AISI 304	AISI 304	1	200	Screw	Stainless steel A2 UNI7323	Stainless steel A2 UNI7323	8-12

[1] FPM for 3PH-3PHS version

[2] See constructions mechanical seal pages 56/57



### 3M (3LM) UP TO 1.1 KW

### 2 POLES

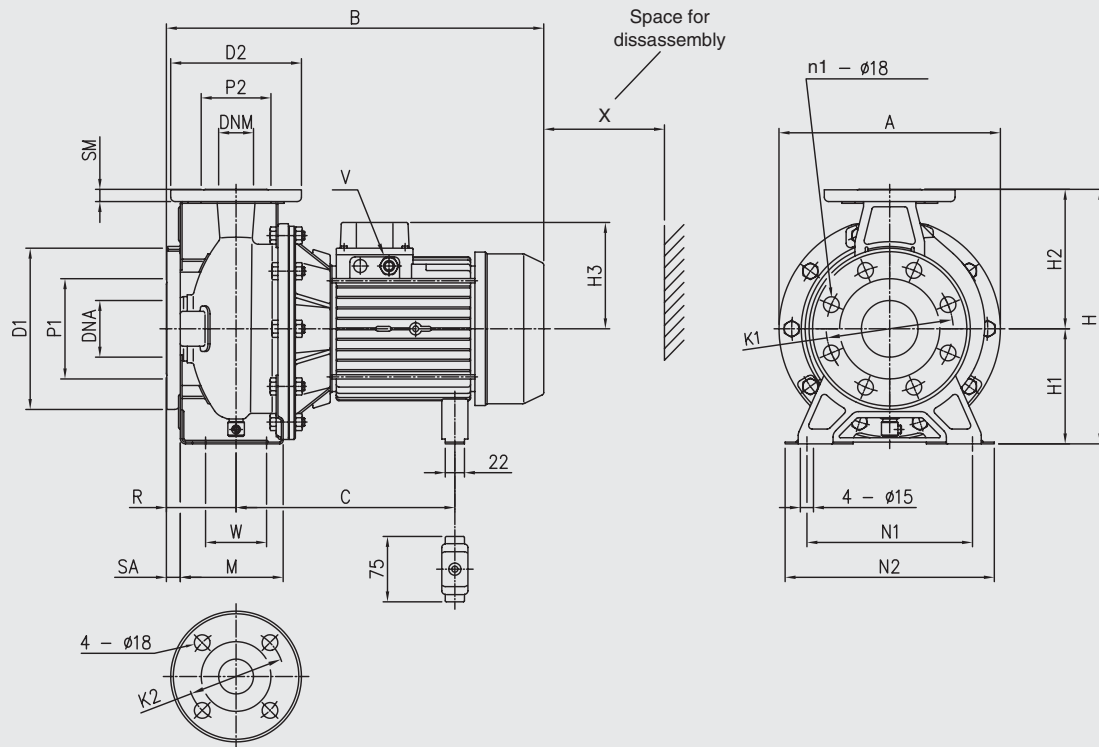

Dimensional table

Model 3(L)M	Dimensions (mm)																				Weight kg							
	∅ DNA	∅ DNM	∅ P1	n1 [1] [2]	∅ K1	∅ D1	SA	∅ P2	∅ K2	∅ D2	SM	H	H1	H2	[3]	H3 [4]	R	W	N1	M		N2	A	B	C	V	X	
32-125/1,1 (M)	50	32	96	4	-	125	165	16	76	100	140	14	252	112	140	122	139	80	70	140	114	190	213	408	231	PG 13,5	110	21,5
32-160/1,5 (M)	50	32	96	4	-	125	165	16	76	100	140	14	292	132	160	122	139	80	70	190	118	240	254	408	231	PG 13,5	110	24,2
32-160/2,2 (M)	50	32	96	4	-	125	165	16	76	100	140	14	292	132	160	122	139	80	70	190	118	240	254	408	231	PG 13,5	110	27,3
32-200/3,0	50	32	96	4	-	125	165	16	76	100	140	14	340	160	180	122	-	80	70	190	119	240	296	433	256	PG 13,5	110	34,9
32-200/4,0	50	32	96	4	-	125	165	16	76	100	140	14	340	160	180	134	-	80	70	190	119	240	296	458	256	PG 16	110	42,3
32-200/5,5	50	32	96	4	-	125	165	16	76	100	140	14	340	160	180	153	-	80	70	190	119	240	296	477	276	PG 16	110	53,2
32-200/7,5	50	32	96	4	-	125	165	16	76	100	140	14	340	160	180	153	-	80	70	190	119	240	296	520	276	PG 16	110	65
40-125/1,5 (M)	65	40	116	4	-	145	185	16	81	110	150	14	252	112	140	122	139	80	70	160	114	210	213	408	231	PG 13,5	115	22,3
40-125/2,2 (M)	65	40	116	4	-	145	185	16	81	110	150	14	252	112	140	122	139	80	70	160	114	210	213	408	231	PG 13,5	115	24,7
40-160/3,0	65	40	116	4	-	145	185	16	81	110	150	14	292	132	160	122	-	80	70	190	118	240	254	433	255	PG 13,5	115	30
40-160/4,0	65	40	116	4	-	145	185	16	81	110	150	14	292	132	160	134	-	80	70	190	118	240	254	458	255	PG 16	115	37,6
40-200/5,5	65	40	116	4	-	145	185	16	81	110	150	14	340	160	180	153	-	100	70	212	139	265	296	497	278	PG 16	115	54,5
40-200/7,5	65	40	116	4	-	145	185	16	81	110	150	14	340	160	180	153	-	100	70	212	139	265	296	520	224	PG 16	115	61,6
40-200/11	65	40	116	4	-	145	185	16	81	110	150	14	340	160	180	181	-	100	70	212	139	265	296	577	224	PG 21	115	73,8
50-125/2,2 (M)	65	50	116	4	-	145	185	16	96	125	165	16	292	132	160	122	139	100	70	190	138	240	254	428	231	PG 13,5	125	30
50-125/3,0	65	50	116	4	-	145	185	16	96	125	165	16	292	132	160	122	-	100	70	190	138	240	254	453	255	PG 13,5	125	31,5
50-125/4,0	65	50	116	4	-	145	185	16	96	125	165	16	292	132	160	134	-	100	70	190	138	240	254	478	255	PG 16	125	37,6
50-160/5,5	65	50	116	4	-	145	185	16	96	125	165	16	340	160	180	153	-	100	70	212	139	265	296	497	278	PG 16	125	54
50-160/7,5	65	50	116	4	-	145	185	16	96	125	165	16	340	160	180	153	-	100	70	212	139	265	296	520	224	PG 16	125	61,1
50-200/9,2	65	50	116	4	-	145	185	16	96	125	165	16	360	160	200	181	-	100	70	212	139	265	296	582	239	PG 21	125	67,5
50-200/11	65	50	116	4	-	145	185	16	96	125	165	16	360	160	200	181	-	100	70	212	139	265	296	582	239	PG 21	125	73,5
65-125/4	80	65	134	8	4	160	200	18	115	145	185	16	340	160	180	139	-	100	95	212	149,5	280	254	483	253	PG 16	145	40
65-125/5,5	80	65	134	8	4	160	200	18	115	145	185	16	340	160	180	150	-	100	95	212	149,5	280	254	496	275	PG 16	145	52
65-125/7,5	80	65	134	8	4	160	200	18	115	145	185	16	340	160	180	150	-	100	95	212	149,5	280	254	540	275	PG 16	145	58,5
65-160/7,5	80	65	134	8	4	160	200	18	115	145	185	16	360	160	200	150	-	100	95	212	149,5	280	296	540	275	PG 16	145	62
65-160/9,2	80	65	134	8	4	160	200	18	115	145	185	16	360	160	200	177,5	-	100	95	212	149,5	280	296	593	356	PG 21	145	67
65-160/11	80	65	134	8	4	160	200	18	115	145	185	16	360	160	200	177,5	-	100	95	212	149,5	280	296	593	356	PG 21	145	75,6

[1] Standard  
[2] On request

3M (3LM) 15 ÷ 22 kW

2 POLES

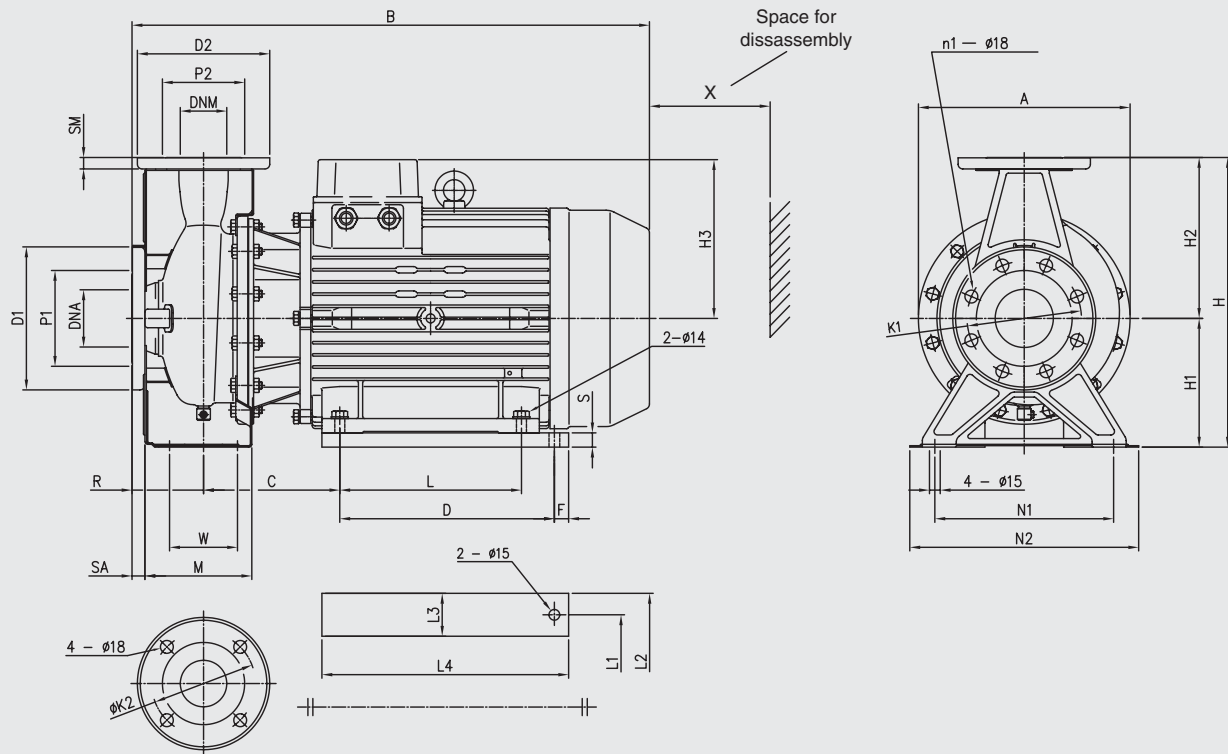

Dimensional table

Model 3(L)M	Dimensions (mm)																												Weight kg					
	∅ DNA	∅ DNM	∅ P1	n1 [1] [2]	∅ K1	∅ D1	∅ SA	∅ P2	∅ K2	∅ D2	∅ SM	H	H1	H2	H3	R	W	N1	M	N2	A	B	L	L1	L2	L3	L4	C		D	F	S	X	
50-200/15	65	50	116	4	-	145	185	16	96	125	165	16	360	160	200	222	100	70	212	139	265	296	723,5	254	254	318	65	304	190,5	-	-	-	125	96
65-160/15	80	65	134	8	4	160	200	18	115	145	185	16	360	160	200	222	100	95	212	149,5	280	296	733	254	254	318	65	304	199,5	-	-	-	145	93
65-200/15	80	65	134	8	4	160	200	18	115	145	185	16	405	180	225	222	100	95	250	149,5	320	296	733	-	258	318	60	345	199,5	300	20	20	145	114
65-200/18,5	80	65	134	8	4	160	200	18	115	145	185	16	405	180	225	222	100	95	250	149,5	320	296	733	-	258	318	60	345	199,5	300	20	20	145	127
65-200/22	80	65	134	8	4	160	200	18	115	145	185	16	405	180	225	222	100	95	250	149,5	320	286	733	-	258	318	60	345	199,5	300	20	20	145	136

[1] Standard  
[2] On request

### 3M4 (3LM4)

### 4 POLES

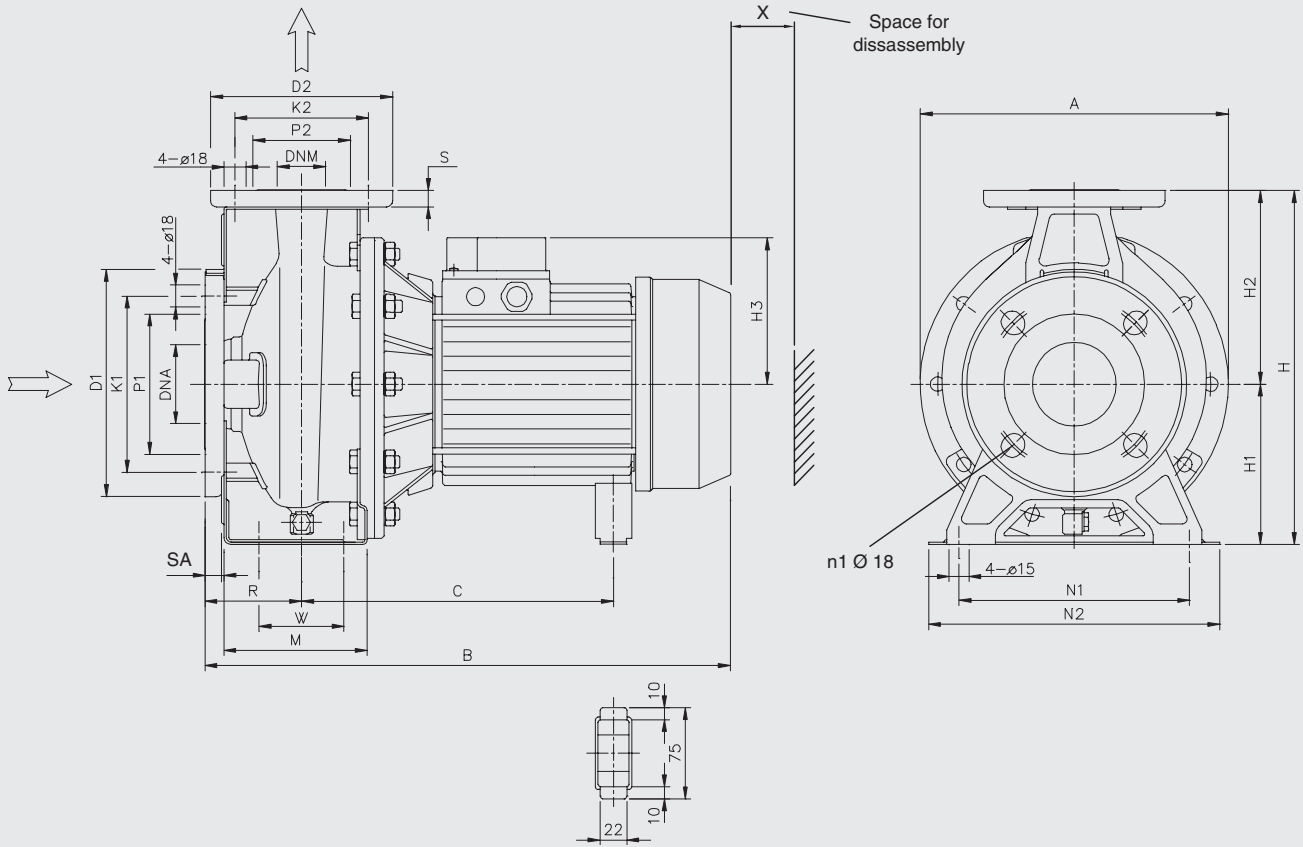

Dimensional table

Model 3(L)M4	Dimensions (mm)																				Weight kg					
	ØDNA	ØDNM	n1		ØK1	ØP1	ØD2	ØK2	ØP2	A	B	C	H	H1	H2	H3	M	N1	N2	R		S	ØD1	SA	W	X
			[1]	[2]																						
32-125/0.25	50	32	4	-	125	96	140	100	76	213	375	205	252	112	140	104	114	140	190	80	14	165	16	70	110	15,0
32-160/0.37R	50	32	4	-	125	96	140	100	76	254	395	222	292	132	160	117	118	190	240	80	14	165	16	70	110	20,0
32-160/0.37	50	32	4	-	125	96	140	100	76	254	395	222	292	132	160	117	118	190	240	80	14	165	16	70	110	20,0
32-200/0.55R	50	32	4	-	125	96	140	100	76	294	395	223	340	160	180	117	119	190	240	80	14	165	16	70	110	25,0
32-200/0.55	50	32	4	-	125	96	140	100	76	294	395	223	340	160	180	117	119	190	240	80	14	165	16	70	110	25,0
32-200/0.75	50	32	4	-	125	96	140	100	76	294	408	232	340	160	180	122	119	190	240	80	14	165	16	70	110	29,3
40-125/0.37R	65	40	4	-	145	116	150	110	81	213	375	205	252	112	140	104	114	160	210	80	14	185	16	70	115	15,0
40-125/0.37	65	40	4	-	145	116	150	110	81	213	375	205	252	112	140	104	114	160	210	80	14	185	16	70	115	15,0
40-160/0.55R	65	40	4	-	145	116	150	110	81	254	395	222	292	132	160	117	118	190	240	80	14	185	16	70	115	20,0
40-160/0.55	65	40	4	-	145	116	150	110	81	254	395	222	292	132	160	117	118	190	240	80	14	185	16	70	115	20,0
40-200/1.1R	65	40	4	-	145	116	150	110	81	294	428	232	340	160	180	122	115	212	265	100	14	185	16	70	115	30,0
40-200/1.1	65	40	4	-	145	116	150	110	81	294	428	232	340	160	180	122	115	212	265	100	14	185	16	70	115	30,0
40-200/1.5	65	40	4	-	145	116	150	110	81	294	428	232	340	160	180	122	115	212	265	100	14	185	16	70	115	32,2
50-125/0.55R	65	50	4	-	145	116	165	125	96	254	415	222	292	132	160	117	114	190	240	100	16	185	16	70	125	20,0
50-125/0.55	65	50	4	-	145	116	165	125	96	254	415	222	292	132	160	117	114	190	240	100	16	185	16	70	125	20,0
50-160/1.1R	65	50	4	-	145	116	165	125	96	296	428	232	340	160	180	122	115	212	265	100	16	185	16	70	125	30,0
50-160/1.1	65	50	4	-	145	116	165	125	96	296	428	232	340	160	180	122	115	212	265	100	16	185	16	70	125	30,0
50-200/1.5R	65	50	4	-	145	116	165	125	96	296	428	232	360	160	200	122	115	212	265	100	16	185	16	70	125	30,0
50-200/1.5	65	50	4	-	145	116	165	125	96	296	428	232	360	160	200	122	115	212	265	100	16	185	16	70	125	30,0
50-200/2.2	65	50	4	-	145	116	165	125	96	296	478	256	360	160	200	134	115	212	265	100	16	185	16	70	125	31,8
65-125/0.55	80	65	8	4	160	134	185	145	115	254	415	219	340	160	180	117	149,5	212	280	100	16	200	18	95	145	22,9
65-125/0.75	80	65	8	4	160	134	185	145	115	254	427	230	340	160	180	123,5	149,5	212	280	100	16	200	18	95	145	27,8
65-125/1.1	80	65	8	4	160	134	185	145	115	254	427	230	340	160	180	123,5	149,5	212	280	100	16	200	18	95	145	28,1
65-160/1.1	80	65	8	4	160	134	185	145	115	296	427	230	360	160	200	123,5	149,5	212	280	100	16	200	18	95	145	30,8
65-160/1.5	80	65	8	4	160	134	185	145	115	296	483	253	360	160	200	123,5	149,5	212	280	100	16	200	18	95	145	32,6
65-160/2.2	80	65	8	4	160	134	185	145	115	296	483	253	360	160	200	139	149,5	212	280	100	16	200	18	95	145	37,8
65-200/2.2R	80	65	8	4	160	134	185	145	115	296	483	253	405	180	225	139	149,5	250	320	100	16	200	18	95	145	38,5
65-200/2.2	80	65	8	4	160	134	185	145	115	296	483	253	405	180	225	139	149,5	250	320	100	16	200	18	95	145	38,7
65-200/3.0	80	65	8	4	160	134	185	145	115	296	483	253	405	180	225	139	149,5	250	320	100	16	200	18	95	145	43,3

[1] Standard  
[2] On request

### 3S (3LS) UP TO 2,2 KW

### 2 POLES

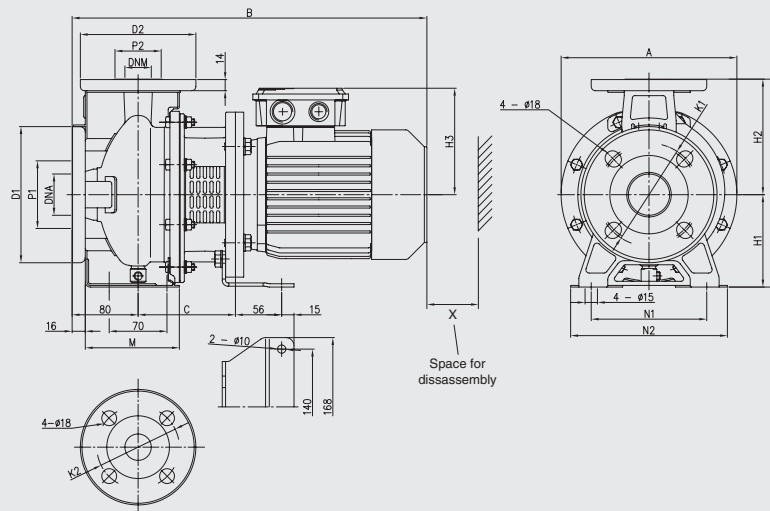

[1] Only for three-phase  
[2] Only for mono-phase

#### Dimensional table

Model 3(L)S	Dimensions (mm)																			Weight kg	
	∅ DNA	∅ DNM	∅ P1	∅ K1	∅ D1	∅ P2	∅ K2	∅ D2	H	H1	H2	H3		N1	M	N2	A	B	C		X
32-125/1,1M	50	32	96	125	165	76	100	140	252	112	140	129	150	140	114	190	213	430	118	110	23,1
32-160/1,5M	50	32	96	125	165	76	100	140	292	132	160	138	160	190	118	240	254	477	130	110	28,5
32-160/2,2M	50	32	96	125	165	76	100	140	292	132	160	138	160	190	118	240	254	477	130	110	32,4
40-125/1,5M	65	40	116	145	185	81	110	150	252	112	140	138	160	160	114	210	213	477	130	115	26,5
40-125/2,2M	65	40	116	145	185	81	110	150	252	112	140	138	160	160	114	210	213	477	130	115	29,6
50-125/2,2M	65	50	116	145	185	95	125	165	292	132	160	138	160	190	138	240	254	497	130	125	32,9

### 3S (3LS) 3 ÷ 4 kW

### 2 POLES

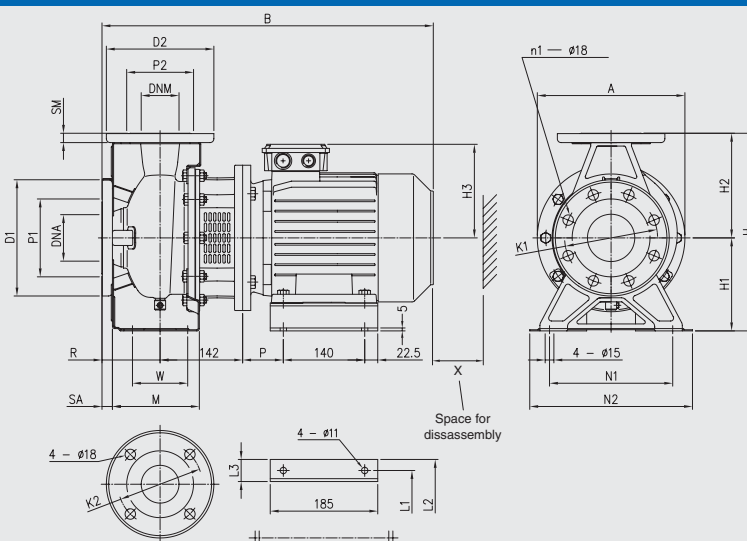

[1] Standard  
[2] On request

#### Dimensional table

Model 3(L)S	Dimensions (mm)																											Weight kg	
	∅ DNA	∅ DNM	∅ P1	n1	∅ K1	∅ D1	SA	∅ P2	∅ K2	∅ D2	SM	H	H1	H2	H3	R	W	N1	M	N2	A	B	L1	L2	L3	P	X		
32-200/3,0	50	32	96	4	-	125	165	16	76	100	140	14	340	160	180	145	80	70	190	119	240	294	528	160	202	42	63	110	43,4
32-200/4,0	50	32	96	4	-	125	165	16	76	100	140	14	340	160	180	161	80	70	190	119	240	294	550	190	228	38	70	110	45,9
65-125/4,0	80	65	134	8	4	160	200	18	115	145	185	16	340	160	180	161	100	95	212	149,5	280	254	615	190	228	38	70	145	47

3S (3LS) 11 ÷ 15 kW

2 POLES

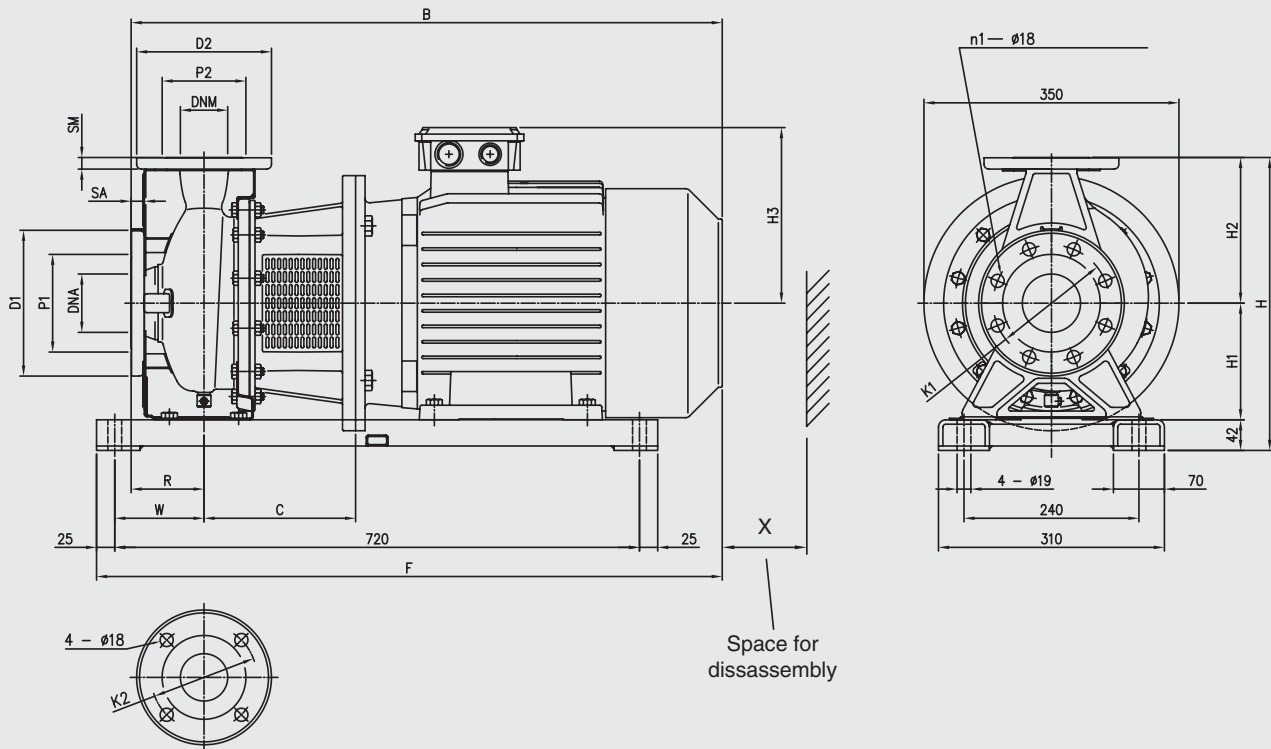

Dimensional table

Model 3(L)S	Dimensions (mm)																					Weight kg	
	Ø DNA	Ø DNM	Ø P1	n1		Ø K1	Ø D1	Ø SA	Ø P2	Ø K2	Ø D2	SM	H	H1	H2	H3	R	W	B	C	F		X
40-200/11	65	40	115	4	-	145	185	16	80	110	150	14	382	160	180	250	100	110	801	198	836	115	107
50-200/11	65	50	115	4	-	145	185	16	95	125	165	16	402	160	200	250	100	110	801	198	836	125	107
50-200/15	65	50	115	4	-	145	185	16	95	125	165	16	402	160	200	250	100	110	801	198	836	125	131
65-160/11	80	65	134	8	4	160	200	18	115	145	185	16	402	160	200	246	100	122,5	801	198	849	145	76
65-160/15	80	65	134	8	4	160	200	18	115	145	185	16	402	160	200	246	100	122,5	811	208	859	145	104

[1] Standard  
[2] On request

3S (3LS)

2 POLES

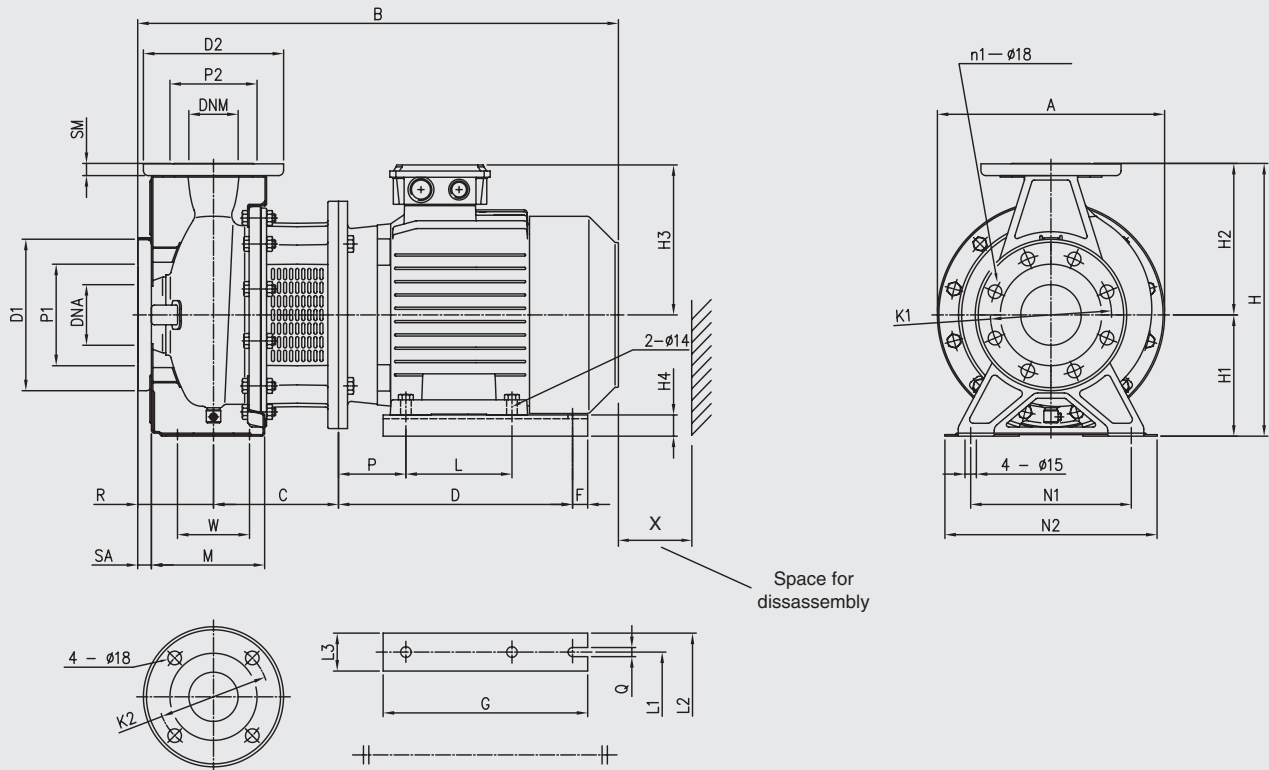

Dimensional table

Model 3(LS)	Dimensions (mm)																											Weight kg								
	∅ DNA	∅ DNM	∅ P1	n1 [1] [2]	∅ K1	∅ D1	∅ SA	∅ P2	∅ K2	D2	SM	H	H1	H2	H3	H4	R	W	N1	M	N2	A	B	C	D	F	L		L1	L2	L3	G	Q	P	X	
32-200/5,5	50	32	96	4	-	125	165	16	76	100	140	14	340	160	180	205	28	80	70	190	119	240	300	615	165	314	15	-	216	266	50	270	12	-	110	62,8
32-200/7,5	50	32	96	4	-	125	165	16	76	100	140	14	340	160	180	205	28	80	70	190	119	240	300	615	165	314	15	-	216	266	50	270	12	-	110	74,6
40-160/3,0	65	40	116	4	-	145	185	16	81	110	150	14	292	132	160	145	32	80	70	190	118	240	254	528	142	246	15	-	160	200	40	220	12	-	115	39
40-160/4,0	65	40	116	4	-	145	185	16	81	110	150	14	292	132	160	161	20	80	70	190	118	240	254	550	142	253	15	-	190	240	50	220	12	-	115	41,5
40-200/5,5	65	40	116	4	-	145	185	16	81	110	150	14	340	160	180	205	28	100	70	212	139	265	300	635	165	314	15	-	216	266	50	270	12	-	115	63,2
40-200/7,5	65	40	116	4	-	145	185	16	81	110	150	14	340	160	180	205	28	100	70	212	139	265	300	635	165	314	15	-	216	266	50	270	12	-	115	69,6
50-125/3,0	65	50	116	4	-	145	185	16	96	125	165	16	292	132	160	145	32	100	70	190	138	240	254	548	142	246	15	-	160	200	40	220	12	-	125	42
50-125/4,0	65	50	116	4	-	145	185	16	96	125	165	16	292	132	160	161	20	100	70	190	138	240	254	570	142	253	15	-	190	240	50	220	12	-	125	42,5
50-160/5,5	65	50	116	4	-	145	185	16	96	125	165	16	340	160	180	205	28	100	70	212	139	265	300	635	165	314	15	-	216	266	50	270	12	-	125	63,8
50-160/7,5	65	50	116	4	-	145	185	16	96	125	165	16	340	160	180	205	28	100	70	212	139	265	300	635	165	314	15	-	216	266	50	270	12	-	125	69,6
50-200/9,2	65	50	116	4	-	145	185	16	96	125	165	16	360	160	200	205	28	100	70	212	139	265	300	673	165	314	15	-	216	266	50	270	12	-	125	79,7
65-125/5,5	80	65	134	8	4	160	200	18	115	145	185	16	340	160	180	198	28	100	95	212	149,5	280	300	635	165	314	15	-	216	266	50	270	12	-	145	60
65-125/7,5	80	65	134	8	4	160	200	18	115	145	185	16	340	160	180	198	28	100	95	212	149,5	280	300	635	165	314	15	-	216	266	50	270	12	-	145	67
65-160/7,5	80	65	134	8	4	160	200	18	115	145	185	16	360	160	200	198	28	100	95	212	149,5	280	300	635	165	314	15	-	216	266	50	270	12	-	145	70
65-160/9,2	80	65	134	8	4	160	200	18	115	145	185	16	360	160	200	198	28	100	95	212	149,5	280	300	673	165	314	15	-	216	266	50	270	12	-	145	77
65-200/15	80	65	134	8	4	160	200	18	115	145	185	16	405	180	225	246	20	100	95	250	149,5	320	350	811	208	413	20	-	254	314	60	350	14	-	145	128
65-200/18,5	80	65	134	8	4	160	200	18	115	145	185	16	405	180	225	246	20	100	95	250	149,5	320	350	855	208	413	20	-	254	314	60	350	14	-	145	141
65-200/22	80	65	134	8	4	160	200	18	115	145	185	16	405	180	225	266	-	100	95	250	149,5	320	350	910	208	-	-	241	279	330	83	-	-	121	145	160

[1] Standard  
[2] On request

### 3S4 (3LS4) UP TO 1,5 KW

### 4 POLES

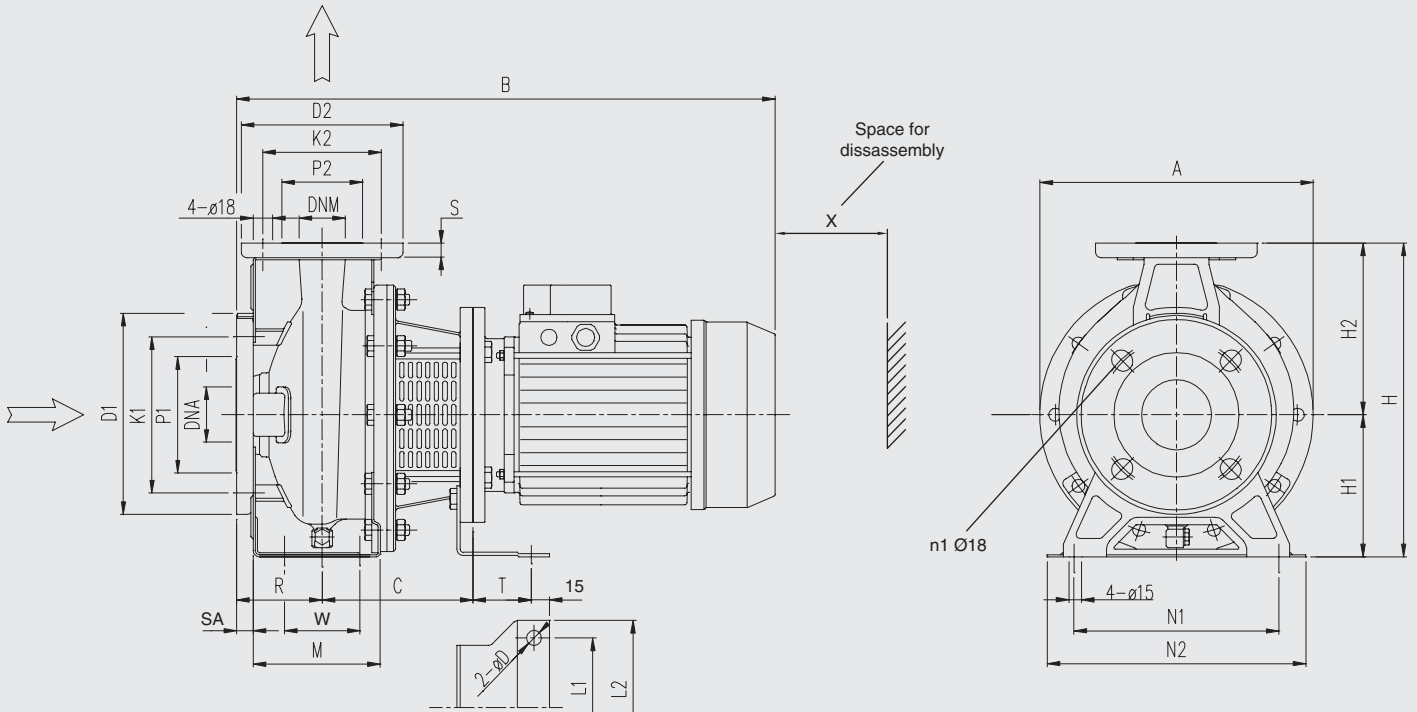

Dimensional table

Model 3(L)S4	Dimensions (mm)																											Weight kg		
	ØDNA	ØDNM	n1	ØD1	SA	ØK1	ØP1	NI	ØD2	ØK2	ØP2	A	B	C	D	H	H1	H2	L1	L2	M	N1	N2	R	W	S	T		X	
32-125/0.25	50	32	4	-	165	16	125	96	4	140	100	76	213	401	108	8	252	112	140	112	140	114	140	190	80	70	14	45	110	15,5
32-160/0.37R	50	32	4	-	165	16	125	96	4	140	100	76	254	401	108	8	292	132	160	112	140	118	190	240	80	70	14	45	110	20,7
32-160/0.37	50	32	4	-	165	16	125	96	4	140	100	76	254	401	108	8	292	132	160	112	140	118	190	240	80	70	14	45	110	20,7
32-200/0.55R	50	32	4	-	165	16	125	96	4	140	100	76	296	435	118	10	340	160	180	140	168	119	190	240	80	70	14	56	110	28,9
32-200/0.55	50	32	4	-	165	16	125	96	4	140	100	76	296	435	118	10	340	160	180	140	168	119	190	240	80	70	14	56	110	28,9
32-200/0.75	50	32	4	-	165	16	125	96	4	140	100	76	296	435	118	10	252	160	180	140	168	119	190	240	80	70	14	56	110	30,1
40-125/0.37R	65	40	4	-	185	16	145	116	4	150	110	81	213	401	118	8	252	112	180	112	140	114	160	210	80	70	14	45	115	17,6
40-125/0.37	65	40	4	-	185	16	145	116	4	150	110	81	213	401	118	8	292	112	140	112	140	114	160	210	80	70	14	45	115	17,6
40-160/0.55R	65	40	4	-	185	16	145	116	4	150	110	81	254	435	118	10	292	132	140	140	168	118	190	210	80	70	14	56	115	23,2
40-160/0.55	65	40	4	-	185	16	145	116	4	150	110	81	254	435	118	10	340	132	160	140	168	118	190	210	80	70	14	56	115	23,2
40-200/1.1R	65	40	4	-	185	16	145	116	4	150	110	81	294	487	130	10	340	160	160	140	168	115	212	265	100	70	14	56	115	33,3
40-200/1.1	65	40	4	-	185	16	145	116	4	150	110	81	294	487	130	10	340	160	180	140	168	115	212	265	100	70	14	56	115	33,3
40-200/1.5	65	40	4	-	185	16	145	116	4	150	110	81	294	512	130	10	292	160	180	140	168	115	212	265	100	70	14	56	115	35,5
50-125/0.55R	65	50	4	-	185	16	145	116	4	150	125	96	254	452	118	10	292	132	160	140	168	114	190	240	100	70	16	56	125	23,5
50-125/0.55	65	50	4	-	185	16	145	116	4	150	125	96	254	452	118	10	340	132	160	140	168	114	190	240	100	70	16	56	125	23,5
50-160/1.1R	65	50	4	-	185	16	145	116	4	150	125	96	296	487	130	10	340	160	180	140	168	115	212	265	100	70	16	56	125	34,0
50-160/1.1	65	50	4	-	185	16	145	116	4	150	125	96	296	487	130	10	360	160	180	140	168	115	212	265	100	70	16	56	125	34,0
50-200/1.5R	65	50	4	-	185	16	145	116	4	150	125	96	296	512	130	10	360	160	200	140	168	115	212	265	100	70	16	56	125	30,0
50-200/1.5	65	50	4	-	185	16	145	116	4	150	125	96	296	512	130	10	360	160	200	140	168	115	212	265	100	70	16	56	125	30,0
65-125/0.55	80	65	8	4	200	18	160	134	8	185	145	115	254	450	118	10	340	160	180	140	168	149,5	212	280	100	95	16	56	145	24,8
65-125/0.75	80	65	8	4	200	18	160	134	8	185	145	115	254	450	118	10	340	160	180	140	168	149,5	212	280	100	95	16	56	145	26
65-125/1.1	80	65	8	4	200	18	160	134	8	185	145	115	254	497	130	10	340	160	180	140	168	149,5	212	280	100	95	16	56	145	30
65-160/1.1	80	65	8	4	200	18	160	134	8	185	145	115	296	497	130	10	360	160	200	140	168	149,5	212	280	100	95	16	56	145	34,1
65-160/1.5	80	65	8	4	200	18	160	134	8	185	145	115	296	497	130	10	360	160	200	140	168	149,5	212	280	100	95	16	56	145	35,2

[1] Standard

[2] On request

3S4 (3LS4) 2,2 ÷ 3 KW

4 POLES

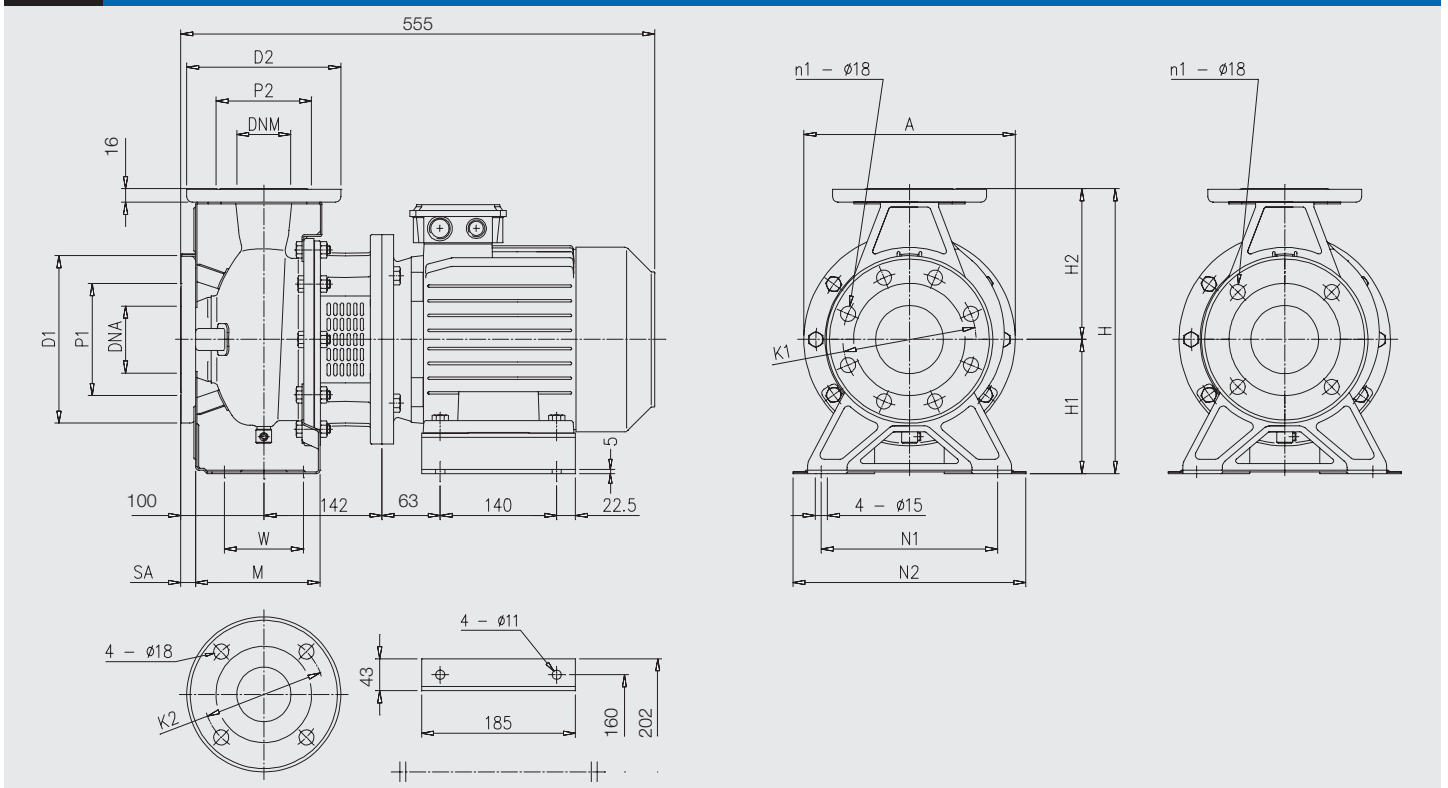

Dimensional table

Model 3(L)S	Dimensions (mm)																			Weight kg
	∅ DNA	∅ DNM	n1 [1]	n1 [2]	∅ P1	∅ K1	∅ D1	SA	∅ P2	∅ K2	∅ D2	H	H1	H2	W	N1	N2	M	A	
50-200/2.2	65	50	4	-	116	145	185	16	96	125	165	360	160	200	70	212	265	139	296	42,8
65-160/2.2	80	65	8	4	134	160	200	18	115	145	185	360	160	200	95	212	280	149,5	296	43,7
65-200/2.2R	80	65	8	4	134	160	200	18	115	145	185	405	180	225	95	250	320	149,5	296	44,8
65-200/2.2	80	65	8	4	134	160	200	18	115	145	185	405	180	225	95	250	320	149,5	296	45
65-200/3.0	80	65	8	4	134	160	200	18	115	145	185	405	180	225	95	250	320	149,5	296	48,2



### 3P (3LP)

### 2 POLES

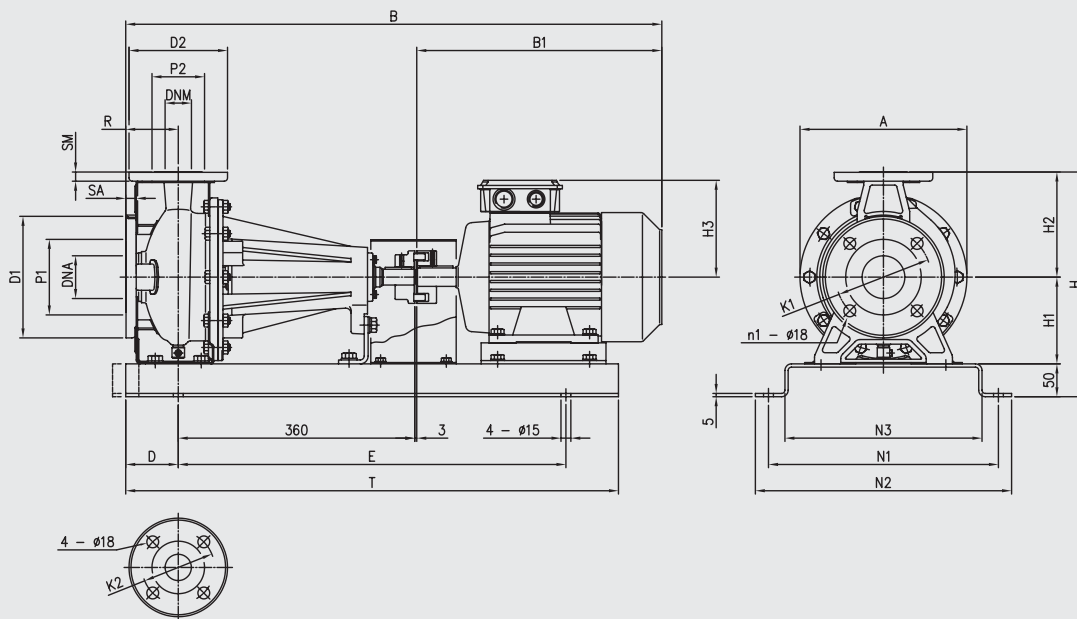

### DIMENSIONAL TABLE

Model 3(L)P	Dimensions (mm)																										Weight kg	
	Ø DNA	Ø DNM	n1 P1	[1]	Ø [2]	Ø K1	D1	SA	Ø P2	Ø K2	Ø D2	SM	H	H1	H2	H3		R	A	B	B1	D	E	N1	N2	N3		T
32-125/1,1 (M)	50	32	95	4	-	125	165	16	75	100	140	14	302	112	140	129	150	80	213	715	272	80	550	300	340	250	710	43,5
32-160/1,5 (M)	50	32	95	4	-	125	165	16	75	100	140	14	342	132	160	138	160	80	254	760	317	80	590	350	390	300	750	51
32-160/2,2 (M)	50	32	95	4	-	125	165	16	75	100	140	14	342	132	160	138	160	80	254	760	317	80	590	350	390	300	750	53,5
32-200/3	50	32	95	4	-	125	165	16	75	100	140	14	390	160	180	145	-	80	296	809	366	80	590	350	390	300	750	68
32-200/4	50	32	95	4	-	125	165	16	75	100	140	14	390	160	180	161	-	80	296	831	388	80	590	350	390	300	750	72
32-200/5,5	50	32	95	4	-	125	165	16	75	100	140	14	390	160	180	198	-	80	296	893	450	100	650	350	390	300	850	88
32-200/7,5	50	32	95	4	-	125	165	16	75	100	140	14	390	160	180	198	-	80	296	893	450	100	650	350	390	300	820	99,8
40-125/1,5 (M)	65	40	115	4	-	145	185	16	80	110	150	14	302	112	140	138	160	80	213	760	317	80	550	300	340	250	710	48,5
40-125/2,2 (M)	65	40	115	4	-	145	185	16	80	110	150	14	302	112	140	138	160	80	213	760	317	80	550	300	340	250	710	51
40-160/3	65	40	115	4	-	145	185	16	80	110	150	14	342	132	160	145	-	80	254	809	366	80	590	350	390	300	750	77,5
40-160/4	65	40	115	4	-	145	185	16	80	110	150	14	342	132	160	161	-	80	254	831	388	80	590	350	390	300	750	64,5
40-200/5,5	65	40	115	4	-	145	185	16	80	110	150	14	390	160	180	198	-	100	296	913	450	100	650	350	390	300	850	89
40-200/7,5	65	40	115	4	-	145	185	16	80	110	150	14	390	160	180	198	-	100	296	913	450	100	650	350	390	300	850	94,5
40-200/11	65	40	115	4	-	145	185	16	80	110	150	14	390	160	180	246	-	100	296	1076	613	100	800	380	420	330	1000	117
50-125/2,2 (M)	65	50	115	4	-	145	185	16	95	125	165	16	342	132	160	138	160	100	254	780	317	80	590	350	390	300	750	132
50-125/3	65	50	115	4	-	145	185	16	95	125	165	16	342	132	160	145	-	100	254	829	366	80	590	350	390	300	750	79
50-125/4	65	50	115	4	-	145	185	16	95	125	165	16	342	132	160	161	-	100	254	851	388	80	590	350	390	300	750	81,5
50-160/5,5	65	50	115	4	-	145	185	16	95	125	165	16	390	160	180	198	-	100	296	913	450	100	650	350	390	300	850	89
50-160/7,5	65	50	115	4	-	145	185	16	95	125	165	16	390	160	180	198	-	100	296	913	450	100	650	350	390	300	850	94,5
50-200/9,2	65	50	115	4	-	145	185	16	95	125	165	16	410	160	200	198	-	100	296	951	488	100	650	350	390	300	850	100
50-200/11	65	50	115	4	-	145	185	16	95	125	165	16	410	160	200	246	-	100	296	1076	613	100	800	380	420	330	1000	117,5
50-200/15	65	50	115	4	-	145	185	16	95	125	165	16	410	160	200	246	-	100	296	1076	613	100	800	380	420	330	1000	125,4
65-125/4	80	65	134	8	4	160	200	18	115	145	185	16	390	160	180	161	-	100	254	851	388	80	590	350	390	300	750	82
65-125/5,5	80	65	134	8	4	160	200	18	115	145	185	16	390	160	180	198	-	100	254	913	450	100	650	350	390	300	850	90
65-125/7,5	80	65	134	8	4	160	200	18	115	145	185	16	390	160	180	198	-	100	254	913	450	100	650	350	390	300	850	97
65-160/7,5	80	65	134	8	4	160	200	18	115	145	185	16	410	160	200	198	-	100	296	913	450	100	650	350	390	300	850	103
65-160/9,2	80	65	134	8	4	160	200	18	115	145	185	16	410	160	200	198	-	100	296	951	450	100	650	350	390	300	850	107
65-160/11	80	65	134	8	4	160	200	18	115	145	185	16	410	160	200	246	-	100	296	1076	613	100	800	380	420	330	1000	114
65-160/15	80	65	134	8	4	160	200	18	115	145	185	16	410	160	200	246	-	100	296	1076	613	100	800	380	420	330	1000	119
65-200/15	80	65	134	8	4	160	200	18	115	145	185	16	455	180	225	246	-	100	296	1076	613	100	800	380	420	330	1000	127
65-200/18,5	80	65	134	8	4	160	200	18	115	145	185	16	455	180	225	246	-	100	296	1120	657	100	800	380	420	330	1000	139
65-200/22	80	65	134	8	4	160	200	18	115	145	185	16	455	180	225	266	-	100	296	1175	712	100	800	410	450	360	1000	182

[1] Standard  
[2] On request

3P (3LP)

4 POLES

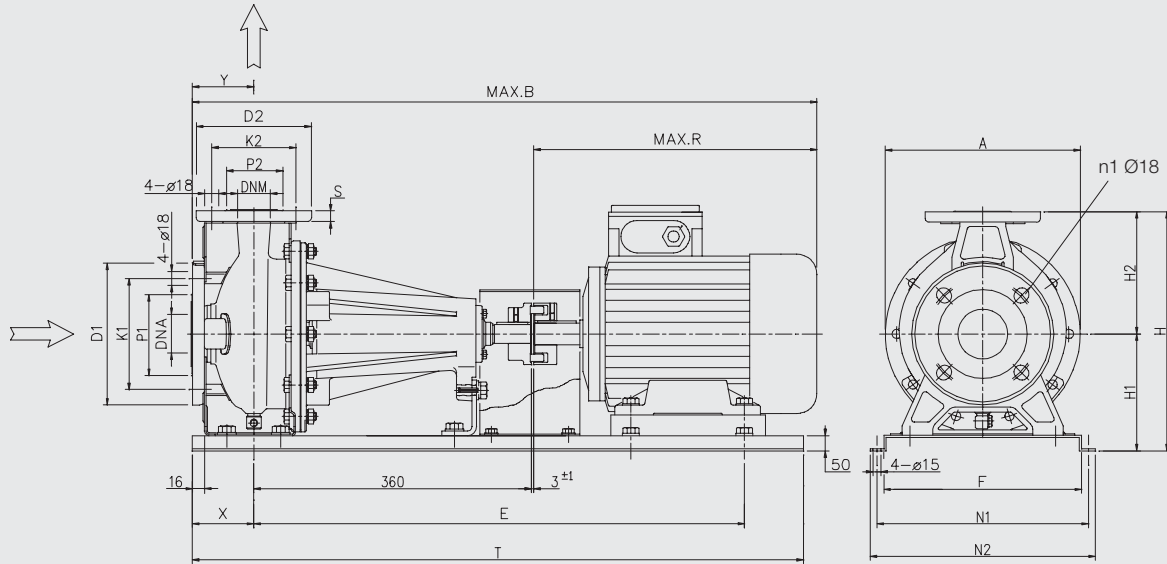

DIMENSIONAL TABLE

Model 3(L)P4	Dimensions (mm)																						Weight kg		
	ØDNA	ØDNM	[1]	n <sup>1</sup> [2]	S	ØD1	ØK1	ØP1	ØD2	ØK2	ØP2	A	B	E	F	H	H1	H2	N1	N2	X	Y		R	T
32-125/0.25	50	32	4	-	14	165	125	95	140	100	75	213	683	550	250	302	162	140	300	340	80	80	240	710	37,0
32-160/0.37R	50	32	4	-	14	165	125	95	140	100	75	254	683	510	300	342	182	160	350	390	80	80	240	670	41,0
32-160/0.37	50	32	4	-	14	165	125	95	140	100	75	254	683	510	300	342	182	160	350	390	80	80	240	670	41,0
32-200/0.55R	50	32	4	-	14	165	125	95	140	100	75	296	717	510	300	390	210	180	350	390	80	80	274	670	53,5
32-200/0.55	50	32	4	-	14	165	125	95	140	100	75	296	717	510	300	390	210	180	350	390	80	80	274	670	53,5
32-200/0.75	50	32	4	-	14	165	125	95	140	100	75	296	717	510	300	390	210	180	350	390	80	80	274	670	54,5
40-125/0.37R	65	40	4	-	14	185	145	115	150	110	80	213	683	550	250	302	162	140	300	340	80	80	240	710	46,5
40-125/0.37	65	40	4	-	14	185	145	115	150	110	80	213	683	550	250	302	162	140	300	340	80	80	240	710	46,5
40-160/0.55R	65	40	4	-	14	185	145	115	150	110	80	254	717	510	300	342	182	160	350	390	80	80	274	670	44,5
40-160/0.55	65	40	4	-	14	185	145	115	150	110	80	254	717	590	300	342	182	160	350	390	80	80	274	670	44,5
40-200/1.1R	65	40	4	-	14	185	145	115	150	110	80	296	795	590	300	390	210	180	350	390	80	80	332	750	61,5
40-200/1.1	65	40	4	-	14	185	145	115	150	110	80	296	795	590	300	390	210	180	350	390	80	80	332	750	61,5
40-200/1.5	65	40	4	-	14	185	145	115	150	110	80	296	795	510	300	390	210	180	350	390	80	80	332	750	64,0
50-125/0.55R	65	50	4	-	16	185	145	115	165	125	95	254	737	510	300	342	182	160	350	390	80	80	274	670	45,0
50-125/0.55	65	50	4	-	16	185	145	115	165	125	95	254	737	590	300	342	182	160	350	390	80	80	274	670	45,0
50-160/1.1R	65	50	4	-	16	185	145	115	165	125	95	296	795	590	300	390	210	180	350	390	80	80	332	750	52,5
50-160/1.1	65	50	4	-	16	185	145	115	165	125	95	296	795	590	300	390	210	180	350	390	80	80	332	750	52,5
50-200/1.5R	65	50	4	-	16	185	145	115	165	125	95	296	795	590	300	410	210	200	350	390	80	80	332	750	64,0
50-200/1.5	65	50	4	-	16	185	145	115	165	125	95	296	795	590	300	410	210	200	350	390	80	80	332	750	64,0
50-200/2.2	65	50	4	-	16	185	145	115	165	125	95	296	863	590	300	410	210	200	350	390	80	80	400	750	70
65-125/0.55	80	65	8	4	16	200	185	134	185	145	115	254	735	510	300	390	160	180	350	390	80	100	272	670	48,6
65-125/0.75	80	65	8	4	16	200	185	134	185	145	115	254	735	510	300	390	160	180	350	390	80	100	272	670	49,8
65-125/1.1	80	65	8	4	16	200	185	134	185	145	115	254	780	590	300	390	160	180	350	390	80	100	317	750	56,1
65-160/1.1	80	65	8	4	16	200	185	134	185	145	115	296	780	590	300	410	160	200	350	390	80	100	317	750	62,6
65-160/1.5	80	65	8	4	16	200	185	134	185	145	115	296	780	590	300	410	160	200	350	390	80	100	317	750	63,7
65-160/2.2	80	65	8	4	16	200	185	134	185	145	115	296	829	590	300	410	160	200	350	390	80	100	366	750	71,5
65-200/2.2R	80	65	8	4	16	200	185	134	185	145	115	296	829	590	330	455	180	225	380	420	80	100	366	750	74,1
65-200/2.2	80	65	8	4	16	200	185	134	185	145	115	296	829	590	330	455	180	225	380	420	80	100	366	750	74,2
65-200/3.0	80	65	8	4	16	200	185	134	185	145	115	296	829	590	330	455	180	225	380	420	80	100	366	750	77,5

[1] Standard  
[2] On request

### 3SF - 3SF4 (3LSF - 3LSF4)

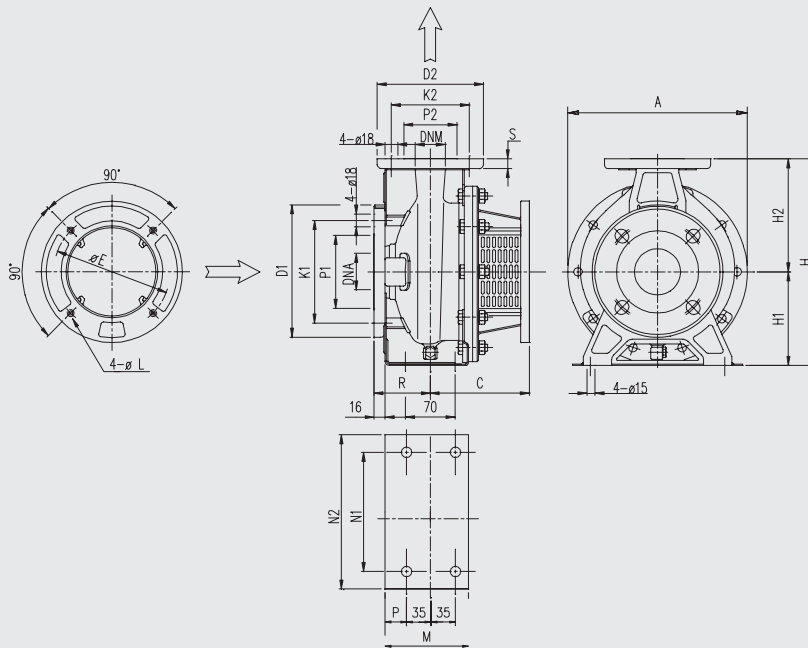

3SF (3LSF) Dimensional table

2 POLES

Model 3(L)SF	Dimensions (mm)																				
	$\phi DNA$	$\phi DNM$	$\phi D1$	$\phi K1$	$\phi P1$	$\phi D2$	$\phi K2$	$\phi P2$	A	C	E	H	H1	H2	L	M	N1	N2	P	R	S
32-125/1,1	50	32	165	125	96	140	100	76	213	118	165	252	112	140	M10	114	140	190	29	80	14
32-160/1,5	50	32	165	125	96	140	100	76	254	130	165	292	132	160	M10	118	190	240	29	80	14
32-160/2,2	50	32	165	125	96	140	100	76	254	130	165	292	132	160	M10	118	190	240	29	80	14
32-200/3	50	32	165	125	96	140	100	76	294	142	215	340	160	180	M12	119	190	240	29	80	14
32-200/4	50	32	165	125	96	140	100	76	294	142	215	340	160	180	M12	119	190	240	29	80	14
32-200/5,5	50	32	165	125	96	140	100	76	294	165	265	340	160	180	M12	119	190	240	29	80	14
32-200/7,5	50	32	165	125	96	140	100	76	294	165	265	340	160	180	M12	119	190	240	29	80	14
40-125/1,5	65	40	185	145	116	150	110	81	213	130	165	252	112	140	M10	114	160	210	29	80	14
40-125/2,2	65	40	185	145	116	150	110	81	213	130	165	252	112	140	M10	114	160	210	29	80	14
40-160/3	65	40	185	145	116	150	110	81	254	142	215	292	132	160	M12	118	190	240	29	80	14
40-160/4	65	40	185	145	116	150	110	81	254	142	215	292	132	160	M12	118	190	240	29	80	14
40-200/5,5	65	40	185	145	116	150	110	81	294	165	265	340	160	180	M12	115	212	265	25	80	14
40-200/7,5	65	40	185	145	116	150	110	81	294	165	265	340	160	180	M12	115	212	265	25	100	14
40-200/11	65	40	185	145	116	150	110	81	294	198	300	340	160	180	M16	115	212	265	25	100	14
50-125/2,2	65	50	185	145	116	165	125	96	254	142	215	292	132	160	M12	114	190	240	25	100	16
50-125/3	65	50	185	145	116	165	125	96	254	142	215	292	132	160	M12	114	190	240	25	100	16
50-125/4	65	50	185	145	116	165	125	96	254	142	215	292	132	160	M12	114	190	240	25	100	16
50-160/5,5	65	50	185	145	116	165	125	96	296	165	265	340	160	180	M12	115	212	265	25	100	16
50-160/7,5	65	50	185	145	116	165	125	96	296	165	265	340	160	180	M12	115	212	265	25	100	16
50-200/9,2	65	50	185	145	116	165	125	96	296	165	265	360	160	200	M12	115	212	265	25	390	16
50-200/11	65	50	185	145	116	165	125	96	296	198	300	360	160	200	M16	115	212	265	25	390	16
50-200/15	65	50	185	145	116	165	125	96	296	198	300	360	160	200	M16	115	212	265	25	390	16

3SF4 (3LSF4) Dimensional table

4 POLES

Model 3(L)SF4	Dimensions (mm)																				
	$\phi DNA$	$\phi DNM$	$\phi D1$	$\phi K1$	$\phi P1$	$\phi D2$	$\phi K2$	$\phi P2$	A	C	E	H	H1	H2	L	M	N1	N2	P	R	S
32-125/0,25	50	32	165	125	96	140	100	76	213	108	130	252	112	140	M8	114	140	190	29	80	14
32-160/0,37R	50	32	165	125	96	140	100	76	254	108	130	292	132	160	M8	118	190	240	29	80	14
32-160/0,37	50	32	165	125	96	140	100	76	254	108	130	292	132	160	M8	118	190	240	29	80	14
32-200/0,55R	50	32	165	125	96	140	100	76	296	118	165	340	160	180	M10	119	190	240	29	80	14
32-200/0,55	50	32	165	125	96	140	100	76	296	118	165	340	160	180	M10	119	190	240	29	80	14
32-200/0,75	50	32	165	125	96	140	100	76	296	118	165	340	160	180	M10	119	190	240	29	80	14
40-125/0,37R	65	40	185	145	116	150	110	81	213	118	130	252	112	140	M8	114	160	210	29	80	14
40-125/0,37	65	40	185	145	116	150	110	81	213	118	130	252	112	140	M8	114	160	210	29	80	14
40-160/0,55R	65	40	185	145	116	150	110	81	254	118	165	292	132	160	M10	118	190	240	29	80	14
40-160/0,55	65	40	185	145	116	150	110	81	254	118	165	292	132	160	M10	118	190	240	29	80	14
40-200/1,1R	65	40	185	145	116	150	110	81	294	130	165	340	160	180	M10	115	212	265	25	100	14
40-200/1,1	65	40	185	145	116	150	110	81	294	130	165	340	160	180	M10	115	212	265	25	100	14
40-200/1,5	65	40	185	145	116	150	110	81	294	130	165	340	160	180	M10	115	212	265	25	100	14
50-125/0,55R	65	50	185	145	116	165	125	96	254	118	165	292	132	160	M10	114	190	240	25	100	16
50-125/0,55	65	50	185	145	116	165	125	96	254	118	165	292	132	160	M10	114	190	240	25	100	16
50-160/1,1R	65	50	185	145	116	165	125	96	296	130	165	340	160	180	M10	115	212	265	25	100	16
50-160/1,1	65	50	185	145	116	165	125	96	296	130	165	340	160	180	M10	115	212	265	25	100	16
50-200/1,5R	65	50	185	145	116	165	125	96	296	130	165	360	160	200	M10	115	212	265	25	100	16
50-200/1,5	65	50	185	145	116	165	125	96	296	130	165	360	160	200	M10	115	212	265	25	100	16
50-200/2,2	65	50	185	145	116	165	125	96	296	130	215	360	160	200	M12	115	212	265	25	100	16

3(L)PF

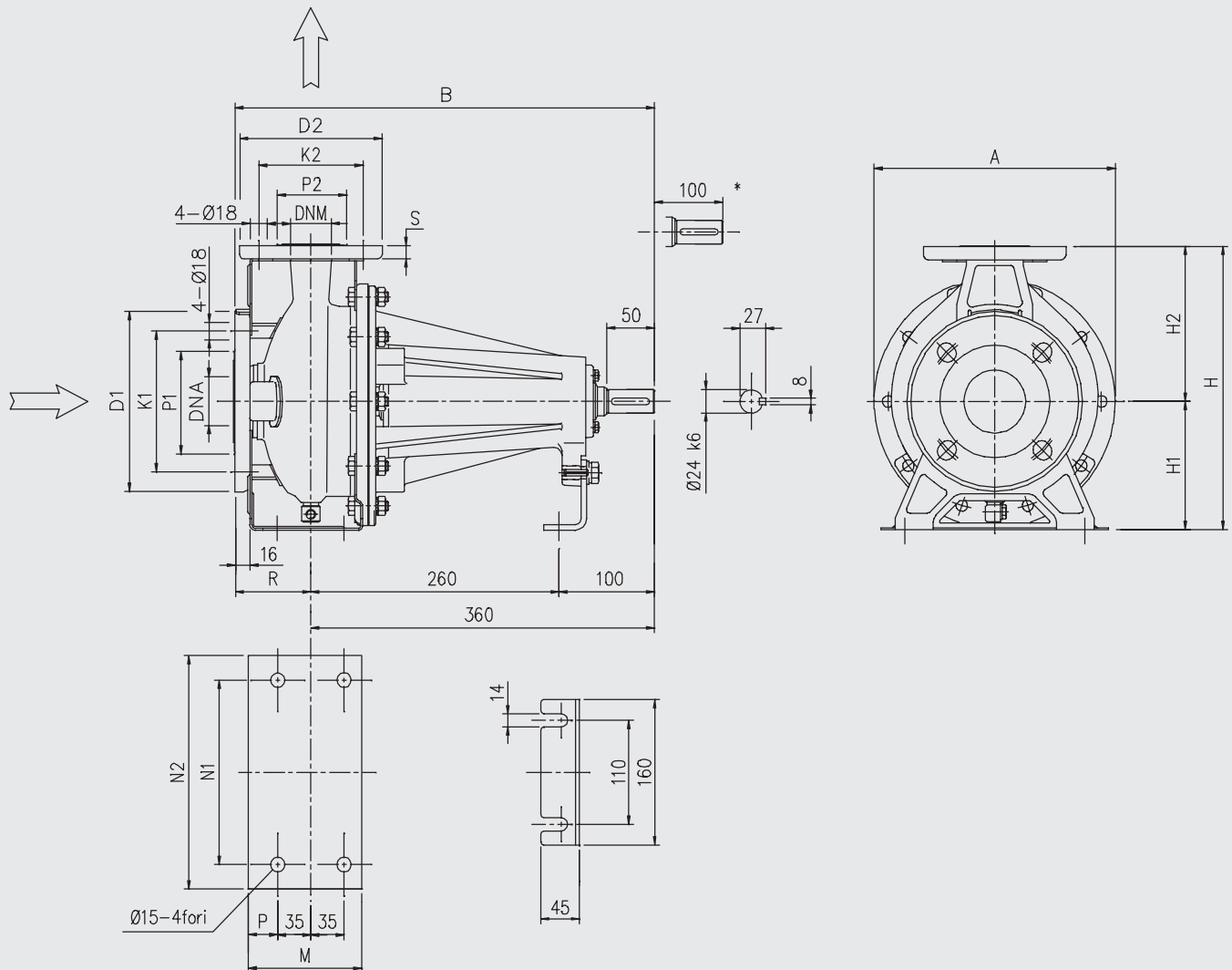

Dimensional table

Model 3(L)PF	Dimensions (mm)																			Weight kg
	ØDNA	ØDNM	ØD1	ØK1	ØP1	ØD2	ØK2	ØP2	A	B	H	H1	H2	M	N1	N2	P	R	S	
32-125	50	32	165	125	95	140	100	75	213	440	252	112	140	114	140	190	29	80	14	18,0
32-160	50	32	165	125	95	140	100	75	254	440	292	132	160	118	190	240	29	80	14	20,0
32-200	50	32	165	125	95	140	100	75	296	440	340	160	180	119	190	240	29	80	14	28,5
40-125	65	40	185	145	115	150	110	80	213	440	252	112	140	114	160	210	29	80	14	18,0
40-160	65	40	185	145	115	150	110	80	254	440	292	132	160	118	190	240	29	80	14	20,0
40-200	65	40	185	145	115	150	110	80	296	460	340	160	180	115	212	265	25	100	14	29,0
50-125	65	50	185	145	115	165	125	95	254	460	292	132	160	114	190	240	25	100	16	20,0
50-160	65	50	185	145	115	165	125	95	296	460	340	160	180	115	212	265	25	100	16	29,0
50-200	65	50	185	145	115	165	125	95	296	460	360	160	200	115	212	265	25	100	16	29,5

### SERIES COUPLING 3S (3LS)

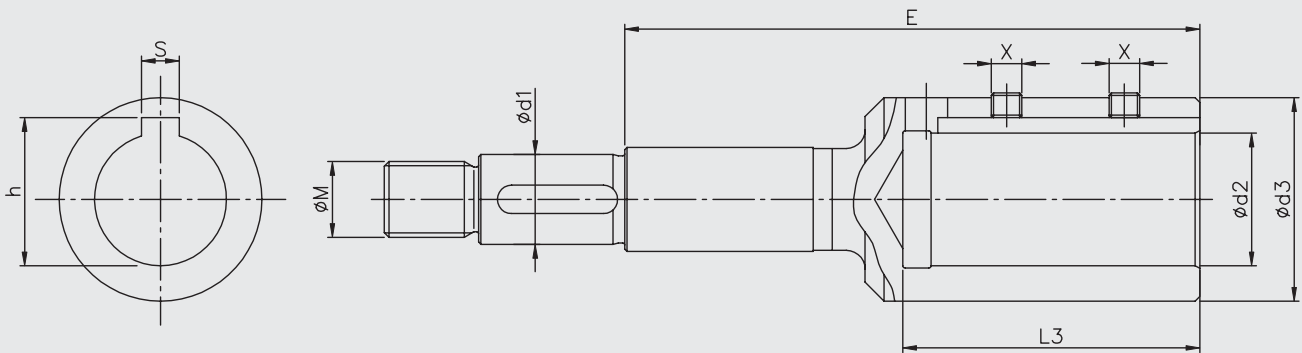

### Dimensional table

2 POLES

Pump Type 3S	Motor		Dimensions (mm)											
	kW	HP	Size	Type	d1	d2	d3	L3	M	X		h	S	E
										Size	Standard			
32-125/N	1,1	1,5	80	B5	19	33	19	43	16 x 1,5	M6 x 6	UNI 5929	21,8	6	98
32-160/R	1,5	2	90	B5	19	39	24	53	16 x 1,5	M8 x 8	UNI 5929	27,3	8	110
32-160/N	2,2	3	90	B5	19	39	24	53	16 x 1,5	M8 x 8	UNI 5929	27,3	8	110
32-200/R	3	4	100	B35	19	43	28	63	16 x 1,5	M8 x 8	UNI 5929	31,3	8	122
32-200/N	4	5,5	112	B35	19	43	28	63	16 x 1,5	M8 x 8	UNI 5929	31,3	8	122
32-200/L	5,5	7,5	132	B35	19	58	38	84	16 x 1,5	M8 x 8	UNI 5929	41,3	10	145
32-200/EL	7,5	10	132	B35	19	58	38	84	16 x 1,5	M8 x 8	UNI 5929	41,3	10	145
40-125/R	1,5	2	90	B5	19	39	24	53	16 x 1,5	M8 x 8	UNI 5929	27,3	8	110
40-125/N	2,2	3	90	B5	19	39	24	53	16 x 1,5	M8 x 8	UNI 5929	27,3	8	110
40-160/R	3	4	100	B35	19	43	28	63	16 x 1,5	M8 x 8	UNI 5929	31,3	8	122
40-160/N	4	5,5	112	B35	19	43	28	63	16 x 1,5	M8 x 8	UNI 5929	31,3	8	122
40-200/R	5,5	7,5	132	B35	19	58	38	84	16 x 1,5	M8 x 8	UNI 5929	41,3	10	145
40-200/N	7,5	10	132	B35	19	58	38	84	16 x 1,5	M8 x 8	UNI 5929	41,3	10	145
40-200/L	11	15	160	B35	19	63	42	114	16 x 1,5	M8 x 8	UNI 5929	45,3	12	178
50-125/S	2,2	3	90	B5	19	39	24	53	16 x 1,5	M8 x 8	UNI 5929	27,3	8	110
50-125/R	3	4	100	B35	19	43	28	63	16 x 1,5	M8 x 8	UNI 5929	31,3	-	122
50-125/N	4	5,5	112	B35	19	43	28	63	16 x 1,5	M8 x 8	UNI 5929	31,3	-	122
50-160/R	5,5	7,5	132	B35	19	58	38	84	16 x 1,5	M8 x 8	UNI 5929	41,3	10	145
50-160/N	7,5	10	132	B35	19	58	38	84	16 x 1,5	M8 x 8	UNI 5929	41,3	10	145
50-200/R	9,2	12,5	132	B35	19	58	38	84	16 x 1,5	M8 x 8	UNI 5929	41,3	10	145
50-200/N	11	15	160	B35	19	63	42	114	16 x 1,5	M8 x 8	UNI 5929	45,3	12	178
50-200/L	15	20	160	B35	22	63	42	114	18 x 1,5	M8 x 8	UNI 5929	45,3	12	209
65-125/R	4	5,5	112	B35	19	28	43	63	16 x 1,5	M8 x 8	UNI 5929	31,3	8	122
65-125/N	5,5	7,5	132	B35	19	38	58	84	16 x 1,5	M8 x 8	UNI 5929	41,3	10	145
65-125/L	7,5	10	132	B35	19	38	58	84	16 x 1,5	M8 x 8	UNI 5929	41,3	10	145
65-160/S	7,5	10	132	B35	19	38	58	84	16 x 1,5	M8 x 8	UNI 5929	41,3	10	145
65-160/R	9,2	12,5	132	B35	19	38	58	84	16 x 1,5	M8 x 8	UNI 5929	41,3	10	145
65-160/N	11	15	160	B35	19	42	63	114	16 x 1,5	M8 x 8	UNI 5929	45,3	12	178
65-160/L	15	20	160	B35	24	42	63	114	20 x 1,5	M8 x 8	UNI 5929	45,3	12	184
65-200/R	15	20	160	B35	24	42	63	114	20 x 1,5	M8 x 8	UNI 5929	45,3	12	184
65-200/N	18,5	25	160	B35	24	42	63	114	20 x 1,5	M8 x 8	UNI 5929	45,3	12	184
65-200/L	22	30	180	B35	24	48	72	114	20 x 1,5	M10 x 10	UNI 5929	51,8	14	184

### Dimensional table

4 POLES

3S4	Motor		Dimensions (mm)											
	kW	HP	Size	Type	d1	d2	d3	L3	M	X		h	S	E
										Size	Standard			
32-125/N	0,25	0,33	71	B5	19	14	28	33	M16 x 1,5	M5 x 6	UNI 5929	16,3	5	88
32-160/R	0,37	0,5	71	B5	19	14	28	33	M16 x 1,5	M5 x 6	UNI 5929	16,3	5	88
32-160/N	0,37	0,5	71	B5	19	14	28	33	M16 x 1,5	M5 x 6	UNI 5929	16,3	5	88
32-200/R	0,55	0,75	80	B5	19	19	33	43	M16 x 1,5	M6 x 6	UNI 5929	21,8	6	98
32-200/N	0,55	0,75	80	B5	19	19	33	43	M16 x 1,5	M6 x 6	UNI 5929	21,8	6	98
32-200/L	0,75	1	80	B5	19	19	33	43	M16 x 1,5	M6 x 6	UNI 5929	21,8	6	98
40-125/R	0,37	0,5	71	B5	19	14	28	33	M16 x 1,5	M5 x 6	UNI 5929	16,3	5	88
40-125/N	0,37	0,5	71	B5	19	14	28	33	M16 x 1,5	M5 x 6	UNI 5929	16,3	5	88
40-160/R	0,55	0,75	80	B5	19	19	33	43	M16 x 1,5	M6 x 6	UNI 5929	21,8	6	98
40-160/N	0,55	0,75	80	B5	19	19	33	43	M16 x 1,5	M6 x 6	UNI 5929	21,8	6	98
40-200/R	1,1	1,5	90	B5	19	24	39	53	M16 x 1,5	M8 x 8	UNI 5929	27,3	8	110
40-200/N	1,1	1,5	90	B5	19	24	39	53	M16 x 1,5	M8 x 8	UNI 5929	27,3	8	110
40-200/L	1,5	2	90	B5	19	24	39	53	M16 x 1,5	M8 x 8	UNI 5929	27,3	8	110
50-125/R	0,55	0,75	80	B5	19	19	33	43	M16 x 1,5	M6 x 6	UNI 5929	21,8	6	98
50-125/N	0,55	0,75	80	B5	19	19	33	43	M16 x 1,5	M6 x 6	UNI 5929	21,8	6	98
50-160/R	1,1	1,5	90	B5	19	24	39	53	M16 x 1,5	M8 x 8	UNI 5929	27,3	8	110
50-160/N	1,1	1,5	90	B5	19	24	39	53	M16 x 1,5	M8 x 8	UNI 5929	27,3	8	110
50-200/R	1,5	2	90	B5	19	24	39	53	M16 x 1,5	M8 x 8	UNI 5929	27,3	8	110
50-200/N	1,5	2	90	B5	19	24	39	53	M16 x 1,5	M8 x 8	UNI 5929	27,3	8	110
50-200/L	2,2	3	100	B35	22	28	43	63	M18 x 1,5	M8 x 8	UNI 5929	31,3	8	153

## JOINT 3P (3LP)

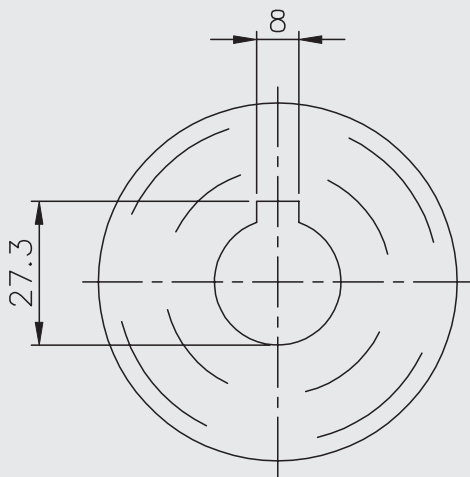

PUMP SIDE

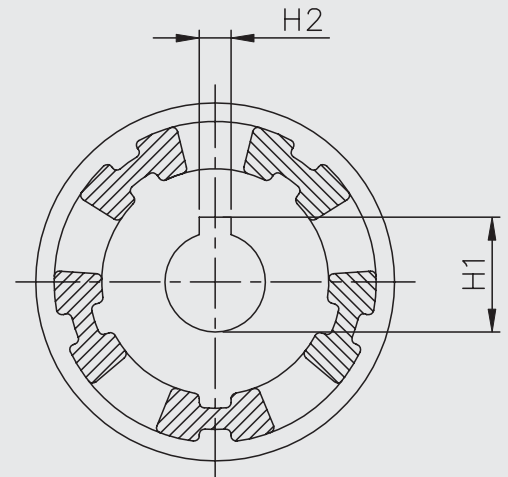
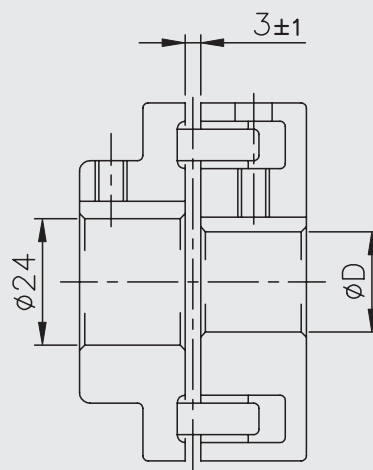

MOTOR SIDE

Dimensional table 2 POLES

Pump Type 3P	kW	HP	Motor		Dimensions (mm)		
			Size	Type	D	H1	H2
32-125/1,1	1,1	1,5	80	B3	19	21,8	6
32-160/1,5	1,5	2	90	B3	24	27,3	8
32-160/2,2	2,2	3	90	B3	24	27,3	8
32-200/3,0	3	4	100	B3	28	31,3	8
32-200/4,0	4	5,5	112	B3	28	31,3	8
32-200/5,5	5,5	7,5	132	B3	38	41,3	10
32-200/7,5	7,5	10	132	B3	38	41,3	10
40-125/1,5	1,5	2	90	B3	24	27,3	8
40-125/2,2	2,2	3	90	B3	24	27,3	8
40-160/3,0	3	4	100	B3	28	31,3	8
40-160/4,0	4	5,5	112	B3	28	31,3	8
40-200/5,5	5,5	7,5	132	B3	38	41,3	10
40-200/7,5	7,5	10	132	B3	38	41,3	10
40-200/11	11	15	160	B3	42	45,3	12
50-125/2,2	2,2	3	90	B3	24	27,3	8
50-125/3,0	3	4	100	B3	28	31,3	8
50-125/4,0	4	5,5	112	B3	28	31,3	8
50-160/5,5	5,5	7,5	132	B3	38	41,3	10
50-160/7,5	7,5	10	132	B3	38	41,3	10
50-200/9,2	9,2	12,5	132	B3	38	41,3	10
50-200/11	11	15	160	B3	42	45,3	12
50-200/15	15	20	160	B3	42	45,3	12
65-125/4,0	4	5,5	112	B3	28	31,3	8
65-125/5,5	5,5	7,5	132	B3	38	41,3	10
65-125/7,5	7,5	10	132	B3	38	41,3	10
65-160/7,5	7,5	10	132	B3	38	41,3	10
65-160/9,2	9,2	12,5	132	B3	38	41,3	10
65-160/11	11	15	160	B3	42	45,3	12
65-160/15	15	20	160	B3	42	45,3	12
65-200/15	15	20	160	B3	42	45,3	12
65-200/18,5	18,5	25	160	B3	42	45,3	12
65-200/22	22	30	180	B3	48	51,8	14

Dimensional table 4 POLES

Pump Type 3P4	kW	HP	Motor		Dimensions (mm)		
			Size	Type	D	H1	H2
32-125/0,25	0,25	0,33	71	B3	14	16,3	5
32-160/0,37R	0,37	0,5	71	B3	14	16,3	5
32-160/0,37	0,37	0,5	71	B3	14	16,3	5
32-200/0,55R	0,55	0,75	80	B3	19	21,8	6
32-200/0,55	0,55	0,75	80	B3	19	21,8	6
32-200/0,75	0,75	1	80	B3	19	21,8	6
40-125/0,37R	0,37	0,5	71	B3	14	16,3	5
40-125/0,37	0,37	0,5	71	B3	14	16,3	5
40-160/0,55R	0,55	0,75	80	B3	19	21,3	6
40-160/0,55	0,55	0,75	80	B3	19	21,3	6
40-200/1,1R	1,1	1,5	90	B3	24	27,3	8
40-200/1,1	1,1	1,5	90	B3	24	27,3	8
40-200/1,5	1,5	2	90	B3	24	27,3	8
50-125/0,55R	0,55	0,75	80	B3	19	21,3	6
50-125/0,55	0,55	0,75	80	B3	19	21,3	6
50-160/1,1R	1,1	1,5	90	B3	24	27,3	8
50-160/1,1	1,1	1,5	90	B3	24	27,3	8
50-200/1,5R	1,5	2	90	B3	24	27,3	8
50-200/1,5	1,5	2	90	B3	24	27,3	8
50-200/2,2	2,2	3	100	B3	28	31,3	8

#### STANDARD MECHANICAL SEAL CONSTRUCTIONS

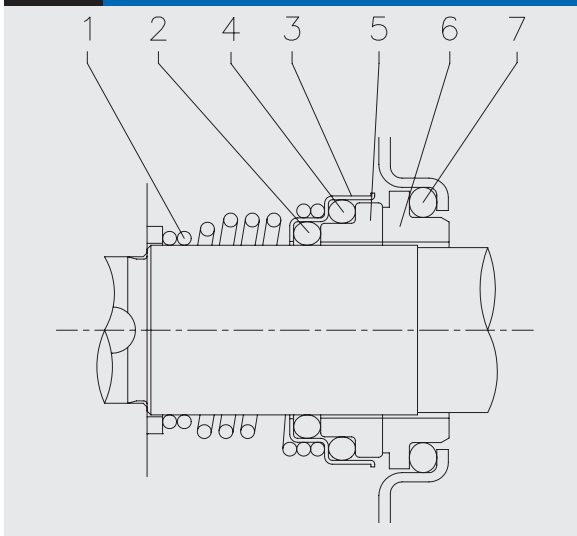

PUMP VERSION		STANDARD	H VERSION
SHAFT DIAMETER		Ø 22 - Ø 30	Ø 22 - Ø 30
MATERIAL	1 Self driving spring	EN 1.4401(AISI 316)	EN 1.4401(AISI 316) EN
	2 O Ring	NBR	FPM
	3 Frame	EN 1.4301(AISI 304)	EN 1.4301(AISI 304)
	4 O Ring	NBR	FPM
	5 Rotary seal ring	ceramic	ceramic
	6 Stationary seal ring	carbon graphite	carbon graphite
	7 O Ring	NBR	FPM

#### HS VERSION MECHANICAL SEAL CONSTRUCTIONS

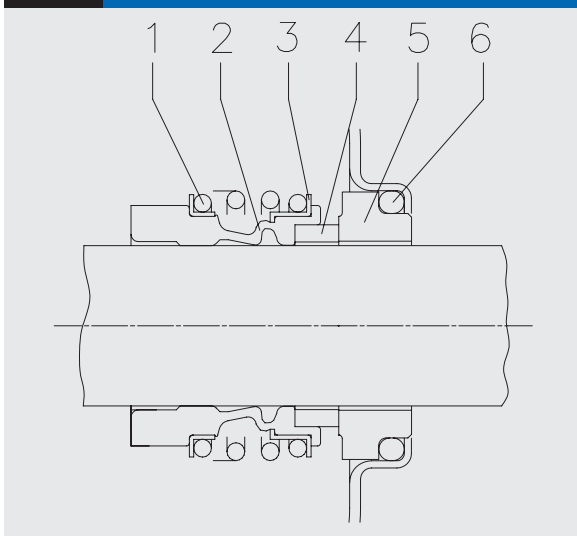

PUMP VERSION		HS VERSION
SHAFT DIAMETER		Ø 22 - Ø 30
MATERIAL	1 Self driving spring	EN 1.4571(AISI 316Ti)
	2 Bellows	FPM
	3 Frame	EN 1.4571(AISI 316Ti)
	4 Rotary seal ring	SiC
	5 Stationary seal ring	SiC
	6 O Ring	FPM

#### 3L SERIES MECHANICAL SEAL CONSTRUCTIONS

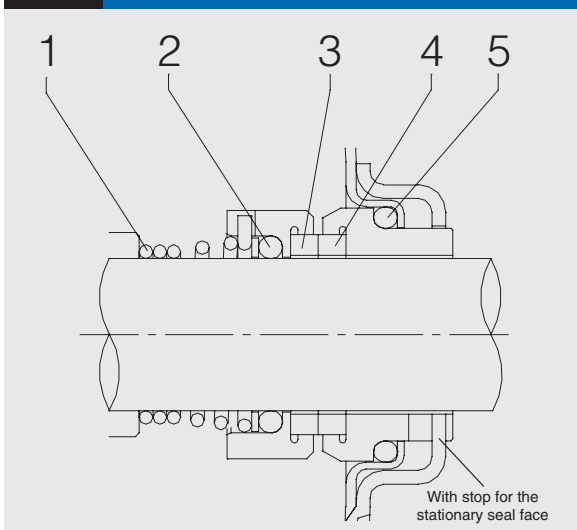

PUMP VERSION		3L
SHAFT DIAMETER		Ø 22 - Ø 30
MATERIAL	1 Self driving spring	AISI 316
	2 O Ring	FPM rubber
	3 Rotary seal ring	SiC
	4 Stationary seal ring	SiC
	5 O Ring	FPM rubber

On request special mechanical seal suitable for different fluids.



### INDICATIVE TABLE OF MECHANICAL SEALS ACCORDING TO FLUID

Type of liquid	Application limit		Type of mechanical seal					
	Conc. % ≤	Temp. °C < ≤	STANDARD Cer/Carb/NBR	H Cer/Carb/FPM	ES1 Sic/Carb/EPDM	ES Sic/Sic/EPDM	HS1 Sic/Carb/FPM	HS Sic/Sic/FPM
Acetic acid	90%	70			■			
Alcohol (ethanol)	100%	50	■		■			
Alkaline cleaning agents (no oil)	5%	70				■		
Ammonia bicarbonate	10%	40			■			
Ammonia water (salmiac)	10%	60	■		■			
Antifreeze (ethylene glycol)	50%	130			■			
Beer		100			■			
Butano		70	■				■	
Citric acid	5%	80			■			
Cooling misture from 0° C to -10°C	30%	100		■				
Cooling misture until -30°C	50%	130			■			
Cooling water (without antifreeze)		60	■	■				
Cooling water, pH < 7.5(with antifreeze)		110		■				
Corn oil		150			■			
Cutting oil (clean)			■				■	
Demineralized water		90	■	■				
Diatermico oil	100%	-5/+110		■				
Diesel oil		70					■	
Distilled water		60	■	■				
Ethanol (alcohol)	100%	50			■			
Ethylene glycol	50%	-20/+90			■			
Foaming detergent		90			■			
Formic acid	1%	20			■			
Glycol - water - mixture		130			■			
Hydrated lime<10%		80				■		
Hydraulic oil (no mineral)		80			■			
Hydrocarbon and derived (max 140°C)		140					■	
Kerosine		80					■	
Lime milk	2%	80				■		
Lubricating oil			■				■	
Methyl alcohol (Methanol)	100%	50	■		■			
Mineral oil		150						■
Oil - water emulsion (clean)		60	■				■	
Oil until 150°C		150					■	
Phosphoric acid	5%	30						■
Polyglycols		90					■	
Propanol (propyl alcohol)		80		■				
Sea Water		40		■				■
Silicone oil		90	■	■				
Sodium bicarbonate	6%	20		■				
Sodium carbonate	6%	60			■			
Sodium hydroxide (caustic soda)	5%	60				■		
Sodium hydroxide (caustic soda)	3%	80			■			
Sodium nitrate	10%	60			■			
Sodium sulphate	5%	60				■		
Soy-bean oil		150						■
Sulphuric acid	2%	20						■
Swimming-pool water		40		■				
Tannery baths		90						■
Thermal water basic		50			■			
Thermal waters acide		50					■	
Vegetable oil, pure		150						■
Vinegar	5%	70	■		■			
Vodka	100%	-5/+80			■			
Washing agents (containing tensides)	10%	70			■			
Water		110		■				
Water for metal cleaning, pH <12		80				■		
Water with marble powder	5%					■		
Wine			■		■			
Wine with infusorial earth						■		

#### POSSIBLE POSITIONS OF INSTALLATION

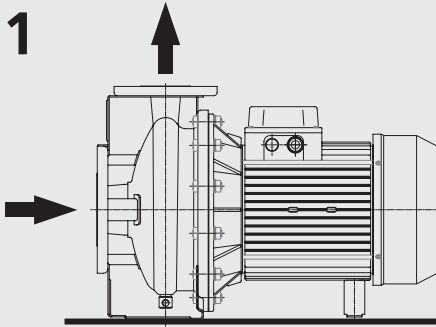

Horizontal position

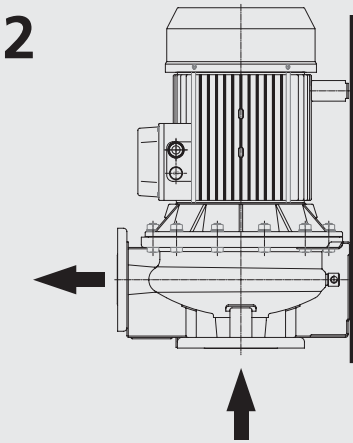

Vertical position  
(please contact our sales network)

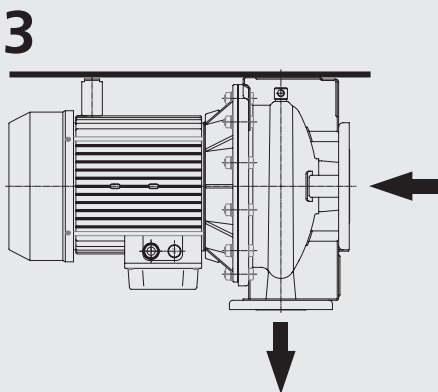

Horizontal position upside down 180°  
(please contact our sales network)

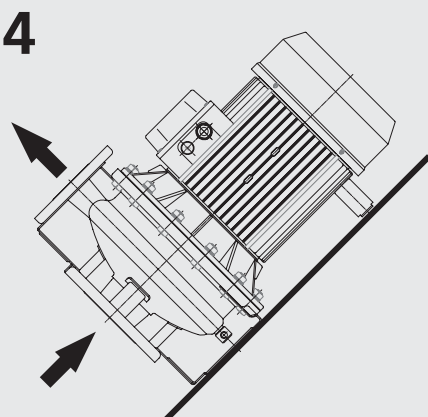

Inclined position

ON REQUEST SPECIAL POSITION  
OF TERMINAL BOX

1

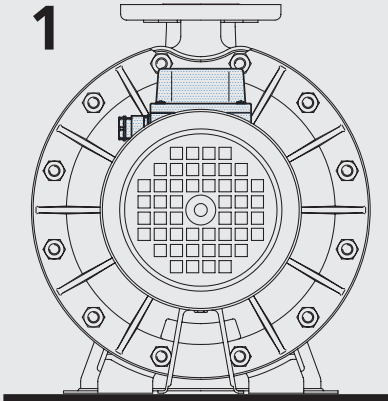

Terminal box on the delivery side standard

2

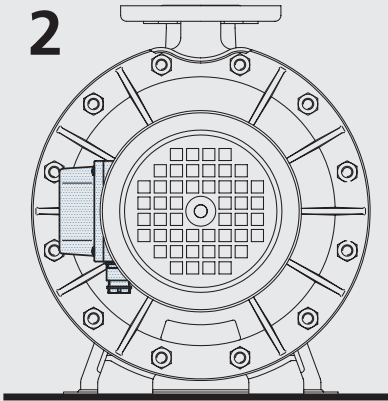

Terminal box on the left of the delivery side

3

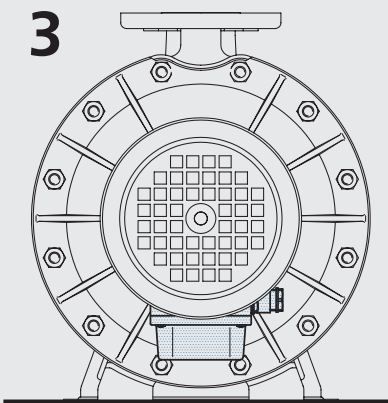

Terminal box opposite delivery side.

4

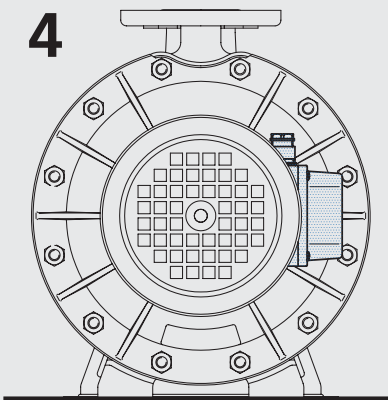

Terminal box on the right of the delivery side.

[www.ebara.eu](http://www.ebara.eu)



**EBARA PUMPS EUROPE S.p.A.**  
Via Pacinotti, 32  
36040 BRENDOLA (VICENZA), Italy  
Phone: +39-0444-706811  
Fax: +39-0444-706950  
Plants: Cles, Brendola  
[www.ebara.it](http://www.ebara.it)